



ES42-5, ES52-5 and CM49 Series

Service Manual

Bulletin No. 2363

November 1988



TABLE OF CONTENTS

SECTION I — GENERAL INFORMATION

SPECIFICATIONS — ES42-5, CM40	2
SPECIFICATIONS — ES52-5, CM49	3
OPERATION	4
SYNCHRONIZER INFORMATION	4
DRIVER INSTRUCTIONS	4

SECTION II — MAINTENANCE

LUBRICATION	5
DISASSEMBLY PRECAUTIONS (TOWING).....	6

SECTION III — CONTROLS

SHIFT TOWER	7
REMOTE CONTROL	8

SECTION IV — DISASSEMBLY

EXPLODED DRAWING — CLUTCH HOUSING & INPUT SHAFT	9
EXPLODED DRAWING — CASE GROUP	10
CASE DISASSEMBLY	11

SECTION V — MAINSHAFT

EXPLODED DRAWING — GEAR GROUP	15
MAINSHAFT DISASSEMBLY — REASSEMBLY	16
INSPECTION PROCEDURES & TORQUE SPECIFICATIONS	20

SECTION VI — REASSEMBLY

CASE REASSEMBLY	21
-----------------------	----

SECTION VII

TROUBLESHOOTING	26
-----------------------	----

SPECIFICATIONS

General Application Guidelines

GVW: 50,000 lbs. on highway
35,000 lbs. on/off highway

HP Range: To 185 HP

RPM Range: To 4000 RPM

Engine Types: Mid-range diesel
gas

Gear Ratios

Models ES42-5A, 4054-A			Models ES42-5D, 4054-D		
Gear	Ratio	% Step	Gear	Ratio	% Step
1	7.22	86	1	7.22	86
2	3.88	75	2	3.88	75
3	2.21	56	3	2.21	76
4	1.42	42	4	1.26	26
5	1.00		5	1.00	
R	7.22		R	7.22	

**Specifications for ES42-5 and 4054 Series
Models ES42-5A, ES42-5D, 4054-A, 4054-D**

Speeds.....5 forward/1 reverse

Torque Capacity420 lbs. ft. (569 nm)

Length25.96 with deep bell
24.21 shallow bell

Weight.....188 lbs. (85 kg) Gas version
200 lbs. (91 kg) Diesel version

Clutch HousingSAE No. 2. Apron front
available for gas

Clutch13" single or 2-plate,
14" single plate, push or pull

Yoke or Flange.....1480, 1550, 1610 series

Input Shaft1½", 1¾", 1¾" available

Oil Capacity12 pints (5.7 litres)

BrakeOptional mounting

Speedometer Drive.....Provision in the rear bearing cap for installation.

Power Take-OffS.A.E. standard 6-bolt, right and left.

P.T.O Drive Speed.....490 RPM per 1000 RPM engine speed

SPECIFICATIONS

General Application Guidelines	
GVW:	60,000 lbs.
HP Range:	160-210
Governed RPM Range:	2200-3800
Engine Types:	Lower hp diesel and mid-range gas engines

Gear Ratios					
Models ES52-5A, 4954-A			Models ES52-5D, 4954-D		
Gear	Ratio	% Step	Gear	Ratio	% Step
1	7.25	82	1	7.25	82
2	3.98	78	2	3.98	78
3	2.23	55	3	2.23	73
4	1.44	44	4	1.29	29
5	1.00		5	1.00	
R	7.25		R	7.25	

**Specifications for ES52-5, CM49 Series
Models ES52-5A, ES52-5D, 4954-A, 4954-D**

- Speeds.....5 forward/1 reverse
- Torque CapacityTo 520 lbs. ft.
- Length*27.045" (687mm) deep bell
25.30" (643mm) shallow bell
- Weight.....240 lbs. (108.9 kg) diesel version
- Clutch HousingSAE No. 2. Apron front
available for gas
- Clutch13" or 14" push or pull, single
or two plate
- Companion Flanges1480 & 1550
- End Yokes1480, 1550 & 1610
- Input Shaft1 3/8", 1 1/2", 1 3/4" available
- Oil Capacity13 pints (6.16 litres)
- BrakeOptional mounting
- Speedometer Drive.....Provision in the rear bearing cap for installation.
- Power Take-OffStandard 6-bolt left and right side,
countershaft rear PTO mount optional
- PTO Drive Speed.....477 RPM per 1000 RPM engine speed

**From bell housing facing to end of splines on output shaft.*

OPERATION

Replacement Parts

The exploded views of sub-assemblies which are incorporated here are for the mechanic's convenience and show the latest material. The parts are arranged in their correct order and may also be used as a reference for assembly or disassembly of this unit.

Synchronizer Information

A synchronized transmission helps the driver make clash free shifts. These transmissions are not synchronized in first and reverse gears because these gears are normally selected when the vehicle is stationary. No synchronizing of engine speed and road speed is required to get in gear from a stop. In fact a synchronizer could cause hard shifting in these two gear positions because a synchronizer needs a gear rotation to do its job. To use the synchronizer properly and receive the benefits of clash free shifts, you should understand how it works.

The purpose of the synchro is to simplify shifting and help the driver get a clash free shift. When a shift is required, the operator declutches, moves the lever toward the desired gear. When the synchronizer ring makes contact with the desired gear, the blockers automatically prevent the shift collar from completing the shift until the gear and mainshaft speeds are matched. At that time the blocker neutralizes automatically and the clash free shift is the result. It must be noted that a steady pressure on the shift lever helps the synchro do its job quickly. When synchronized, the lever moves into gear smoothly and easily.

If the driver jabs at the synchro or "teases" the synchro by applying pressure and releasing pressure, to apply pressure again the synchro cannot do its job. It takes a second or two to match speeds and the constant pressure assures the faster synchro action. It is possible to override a blocker if the lever is "forced" into gear. This, of course, defeats the purpose of the synchro and can cause gear clash which is damaging to the life of the transmission.

Driver Instructions

Depress clutch, wait for complete release, move lever into 1st and accelerate to an RPM that will allow enough momentum to select the next higher gear and still have vehicle acceleration after completing the shift into 2nd gear. This is using the progressive shift technique. By doing so, you save fuel. There is usually no reason to go all the way to the governor before you shift to second. This method can vary depending on the GVW of the vehicle, road condition as well as the type of service. When second is desired, proceed as follows: Declutch, move the lever toward second gear. Keep a steady pressure on the lever. The synchronizer will pick up 2nd gear and synchronize its speed to the mainshaft speed. When synchronized, the lever moves easily into 2nd. Continue in the same manner to top road speed. Notice as you approach the top speed, you must accelerate closer to the governed speed before you allow the engine to drop to the next gear shift point to have good performance. This is because air resistance at higher speeds require more of the available horsepower to get adequate performance. Of course you receive maximum performance and horsepower at governed speed.

When you downshift, the same procedure for shifting the transmission will be used, except that the engine RPM will be raised to the governor as the clutch is engaged after completing the shift. You would do it this way. In top gear as you approach the shift point (normally the shift starts about 100 RPM over the shift point), declutch and move the shift lever with a steady even pressure toward 4th gear. The synchronizer will pick up 4th gear and speed it up to vehicle speed and allow a clash free shift from 5th to 4th. After the shift, reengage the clutch at the same time accelerate the engine to keep the vehicle moving at the desired speed. If further downshifts are required, continue in a similar manner.

Remember that when downshifting into 1st gear, that 1st is not synchronized and will require a double clutch operation to complete a clash free shift.

Of course you can double clutch on all shifts if you desire. This only aids the synchronizer in its job function by manually helping to get the engine speed and road speed matched.

Spicer® Transmission Lubrication

To insure proper lubrication and operating temperatures in these units, it is important that proper lubricants be used and correct oil levels be maintained.

Recommended Lubricants

The lubricants listed below are recommended, in order of preference, for use in all Spicer mechanical transmissions, auxiliaries and transfer cases.

DO NOT USE EXTREME PRESSURE ADDITIVES, such as found in multi-purpose or rear axle type lubricants. These additives are not required in Spicer transmissions, and in some cases may create transmission problems. Multi-purpose oils, as a group, have relatively poor oxidation stability, a high rate of sludge formation and a greater tendency to react on or corrode the steel and bronze parts.

Oil Changes

We recommend an initial oil change and flush after the transmission is placed in actual service. This change should be made any time following 3000 miles (4827 km), but never exceed 5000 miles (8045 km) of over-the-road service. In off-highway use, the change should be made after 24 hours—but before 100 hours—of service have been completed.

Many factors influence the following oil change periods. Therefore, a definite mileage interval is not specified here. In general, however, it is suggested that a drain and flush be scheduled every 50,000 miles (80,450 km) for normal over-the-highway operations. Off-highway uses usually require an oil change every 1000 hours. The oil level in the transmission should be checked every 5000 miles (8045 km) on-highway, or every 40 hours in off-highway operation. When it is necessary to add oil, we recommend that types or brands of oil not be mixed. The correct oil level in all Spicer transmissions is established by the filler plug opening.

Refill

First, remove all dirt around the filler plug. Then refill the transmission with new oil. Use the grade recommended for the existing season and prevailing service. The lubricant should be level with the oil fill plug located on the right side of the transmission case.

Overfilling

Do not overfill the transmission. This usually results in oil breakdown due to excessive heat and aeration from the churning action of the gears. Early breakdown of the oil will result in heavy varnish and sludge deposits that plug up oil ports and build up on splines and bearings. Oil overflow escapes onto the clutch or parking brakes, causing additional trouble.

TEMPERATURE	GRADE	TYPE
Above 0° F (–18° C) Below 0° F (–18° C)	SAE 30, 40, or 50 SAE 30	Heavy duty engine oil meeting MIL-L-2104D or MIL-L-46152B, API-SF or API-CD. (MIL-L-2104 B & C, or 46152 are also acceptable.)
Above 0° F (–18° C)	SAE 90	Straight mineral gear oil — R & O Type API-GL-1
Below 0° F (–18° C)	SAE 80	Straight mineral gear oil — R & O Type API-GL-1
All	CD SAE 30 or CD SAE 50	Synthetic engine oil meeting MIL-L-2104D or MIL-L-46152B, API-SF or API-CD

Do not use Extreme Pressure (EP) additives, such as found in multi-purpose or rear axle type lubricants. These additives are not required in Spicer transmissions and may in some cases create transmission problems.

General Precautions for Disassembly

IMPORTANT

Read this section before starting the detailed disassembly procedure.

Follow each procedure closely in each section, making use of both the text and the pictures.

Rebuild Facilities

A suitable holding fixture or overhaul stand is desirable, but not necessary, to rebuild this unit. The flat bottom of the transmission case provides a suitable working platform when the unit is placed on a sturdy shop table.

For easier working conditions, table height should be 28-30 inches. A light chain hoist should be used to handle the mainshaft and countershafts during removal and reassembly procedures.

Cleanliness

Transmissions should be steam cleaned prior to disassembly. Seal all openings before steam cleaning. This will prevent dirt and water entry, which can damage serviceable parts.

Dirt is abrasive and will cause premature wear of bearings and other parts. Therefore, we suggest having a small wash tank nearby so parts can be cleaned prior to reassembly.

Bearings

When a transmission is removed at relatively low mileage, the bearings should be removed with pullers designed for this purpose. Wrap the bearings to keep out dirt. Clean, inspect and lubricate all bearings just prior to reassembly. If mileage or transmission condition warrants a complete overhaul, it is recommended that all bearings be replaced.

End Yokes and Flanges

End yokes and flanges should be installed and removed with the correct drivers and pullers—not with a hammer. Hammering is not only destructive to the yoke or the flange, but also can cause serious internal transmission damage. For example, hammering destroys or mutilates the pilot diameters, as well as warps or bends the flange. Hammering on end yokes will close in the bearing bores or misalign yoke lugs, resulting in early journal needle bearing failures.

In most designs, when the yoke/flange locknuts are tightened and secure, the internal bearings and gears are in proper location. When the yoke/flange is driven on the shaft, however, two conditions can exist.

- (a) If the bearing fit is *tight* on the shaft, usually the bearings will brinell since they absorb the pounding force of the hammer.
- (b) If the bearing fit is *loose*, the shaft will keep moving inward until it is stopped by the internal parts such as the pilot bearing thrust washers and snap rings.

CAUTION

Do not tow vehicle equipped with Spicer transmissions without first pulling the axles or disconnecting the drive shaft. Lubrication of the internal gear train is inadequate when the vehicle is towed.

Shift Tower

Disassembly

1. Remove the retaining capscrews and lockwashers.
2. Position the shift lever dome on edge in a vise.
3. Pull up the grommet. Press the collar against the spring, then remove the lock pin.
4. Slide the compression cup up the shift lever and remove the rock shaft snap ring.
5. Tap the rock shaft free of the dome and remove the shift lever. Now remove and discard the gasket.
6. Remove the shift lever knob and slide the grommet, collar, spring, and cup off the lever.

4. Assemble the rock shaft snap ring to the groove of the dome, locking the rock shaft in place.
5. Next place a new, lightly greased seal on the shift dome. Grease the inner wall of the cup, and slide it over the lever into position on the dome.
6. Assemble the spring, collar and grommet over the shift lever. Depress the collar and insert the collar lock pin through the hole in the lever.
7. Assemble the shift lever knob.
8. Place the shift lever and dome assembly on the shifter housing with a gasket, noting that the finger enters the neutral position notches.
9. Secure the assembly with the capscrews and lockwashers.

Inspection

Wash all parts thoroughly and inspect the lever and rock shaft cross holes for excessive wear.

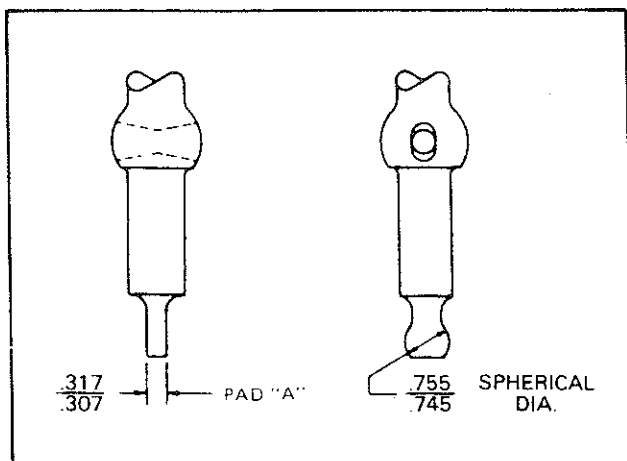

Check the spring tension by comparing the old spring to a new one.

Reassembly

1. Position the shift lever dome on edge in a vise.
2. Hold the shift lever so that the lever cross hole aligns with the rock shaft cross hole in the dome.
3. Insert the rock shaft through the holes in the dome and shift lever.

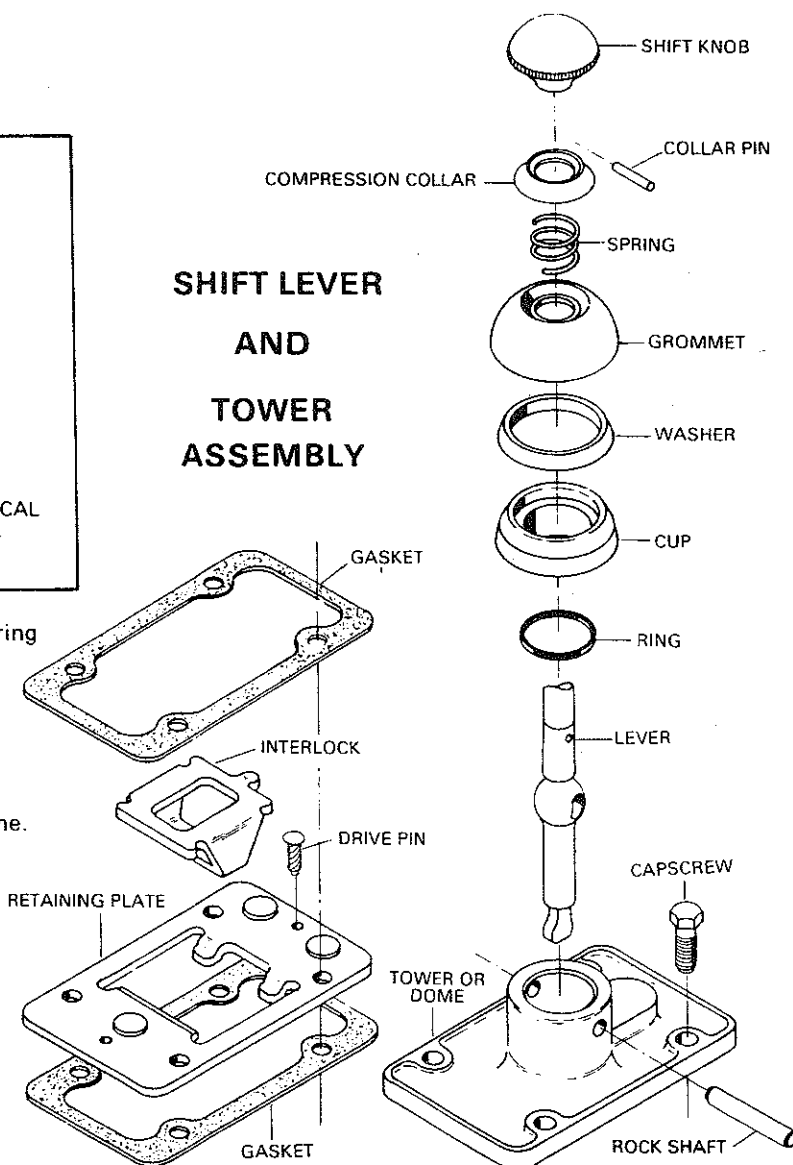

Remote Control

Disassembly

1. Remove the capscrews and separate the remote control from the shifter housing.
2. Remove all retaining capscrews and locknuts from the rod ends.
3. Continue to disassemble the remote housing subassembly, if necessary.
4. Remove the lockwire from the rubber boot.
5. Remove the inner shift finger capscrew, shift finger and key.
6. The shift rail subassembly may now be removed.
7. After removing the capscrew, the outer shift finger can be removed.
8. The oil seal and internal bushings are all that remains.

Reassembly

1. Press both bushings and the oil seal into the housing.
2. Press the shift rail through the outer finger and secure the assembly with a capscrew.
3. Install the rubber boot. Then insert the shift rail subassemblies into the remote housing.
4. Next install the key and the inner finger, securing them with a capscrew.
5. Now, lockwire the rubber boot.
6. Continue the assembly procedure by installing all the capscrews and locknuts through the rod ends.
7. Then, with the bracket, secure the remote control to the transmission shifter housing. Note that the finger enters the neutral position notches.

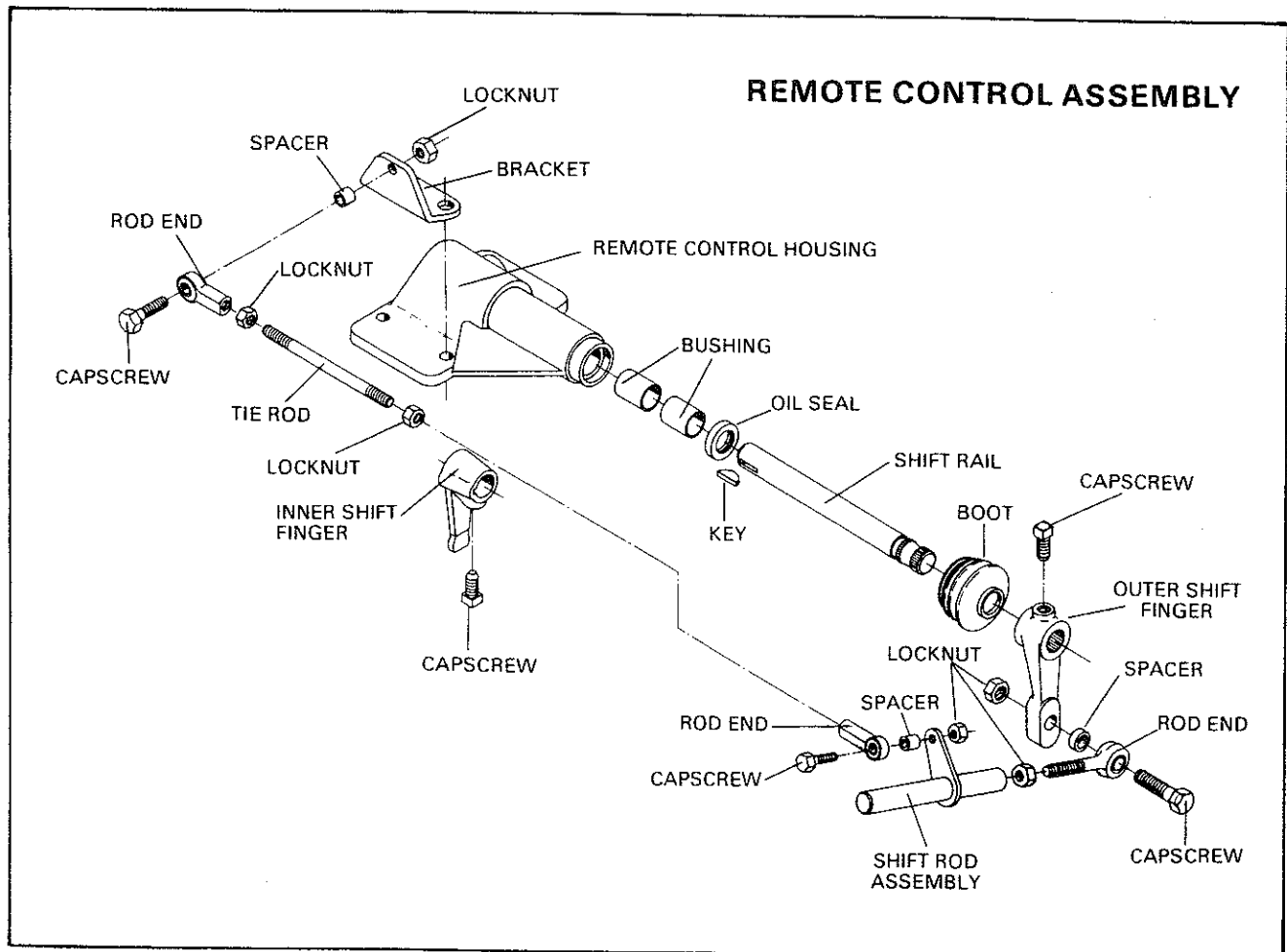

CLUTCH HOUSING & INPUT SHAFT

SECTION IV

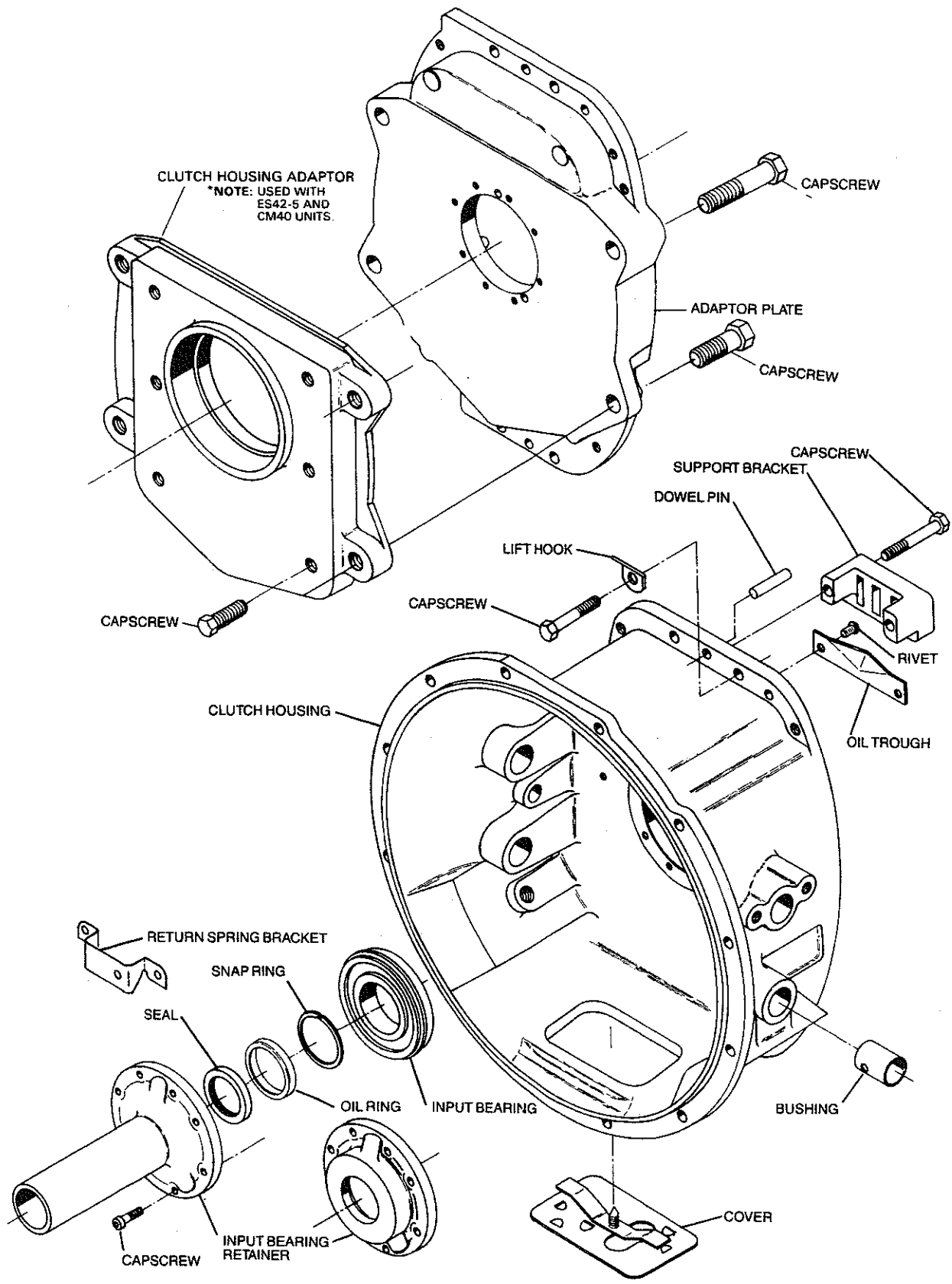

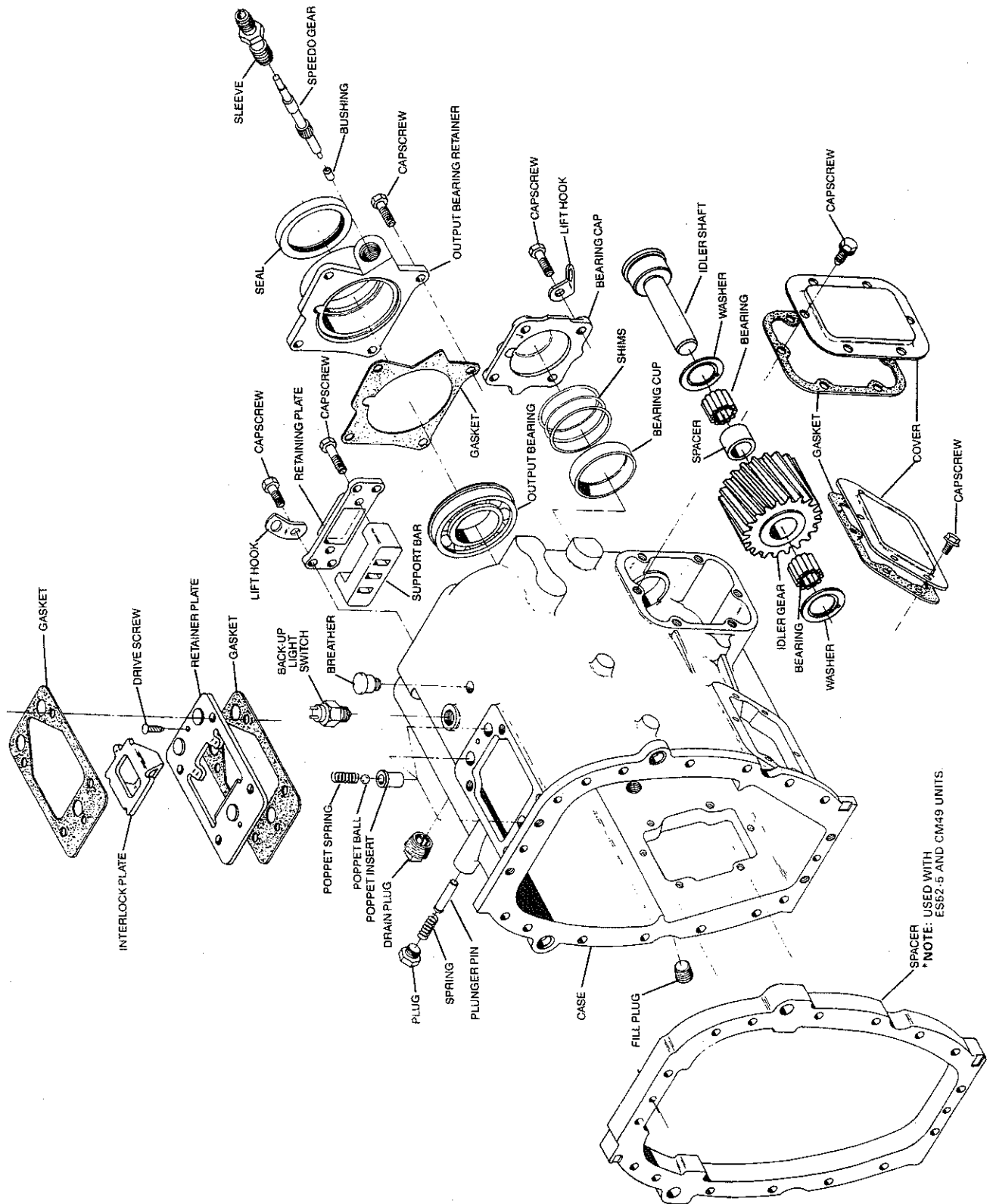

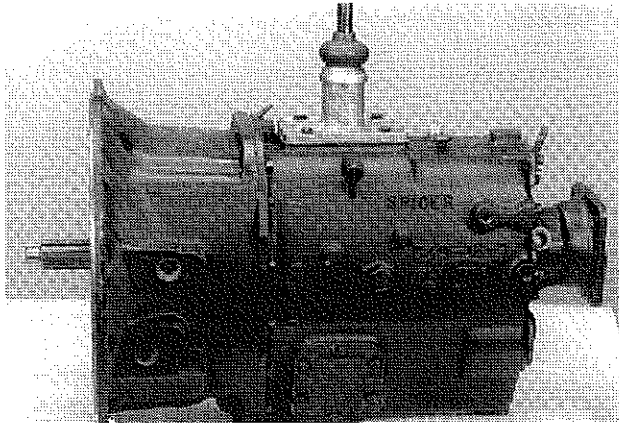

1. Begin the disassembly by removing the shift tower and gasket.

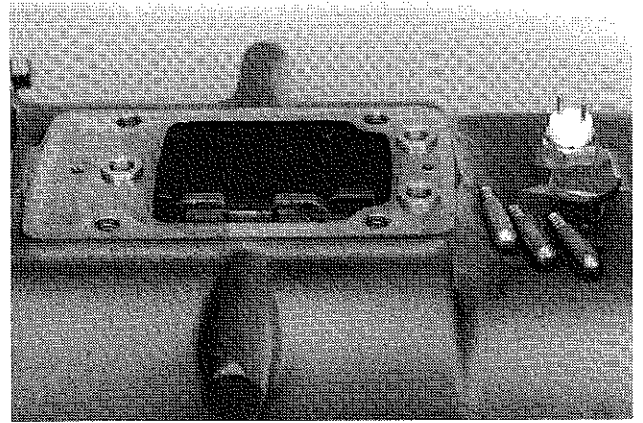

4. The poppet springs and poppet balls should be removed.

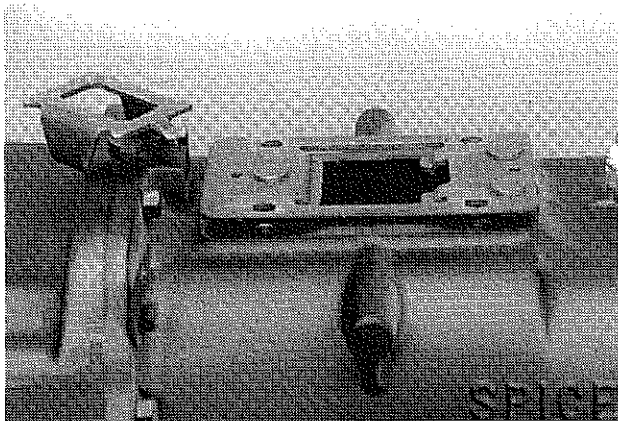

2. Remove the interlock.

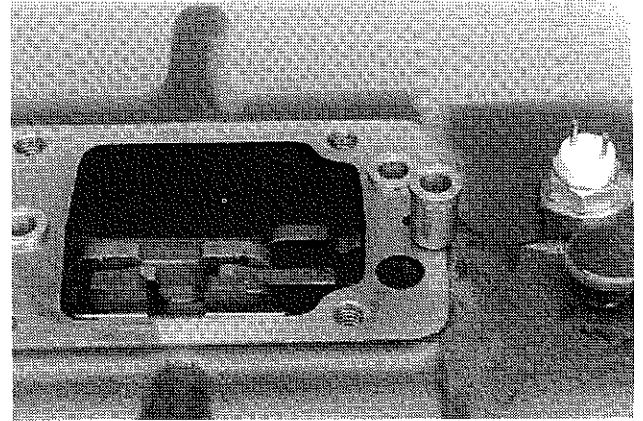

5. These poppet inserts may be replaced, if chipped or elongated.



3. Now, remove the interlock retaining plate and gasket. The two drive pins securing this plate are required during initial manufacturing only, not for service rebuilds.

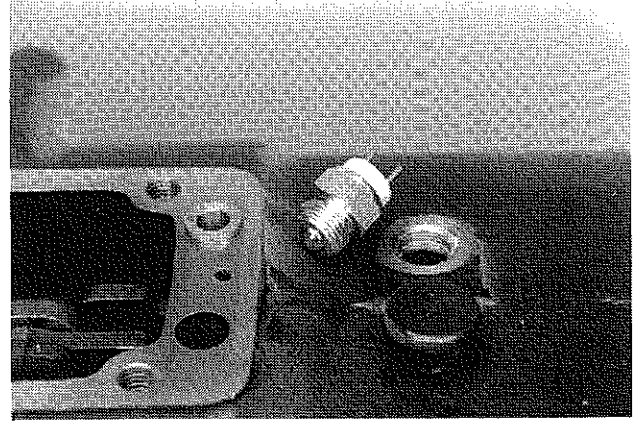

6. Remove the back-up lite switch and shims.

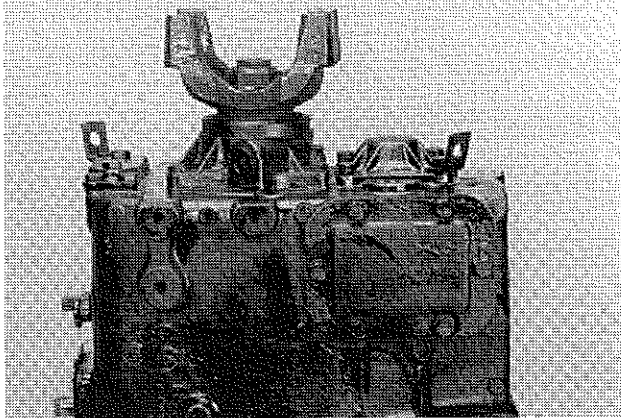

7. Stand the transmission upright and remove the shift bar cap.

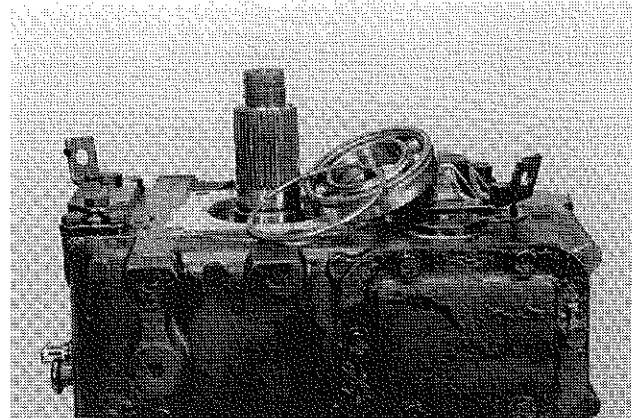

10. Now use either a puller or pry bars in the snap ring groove to remove this output bearing.

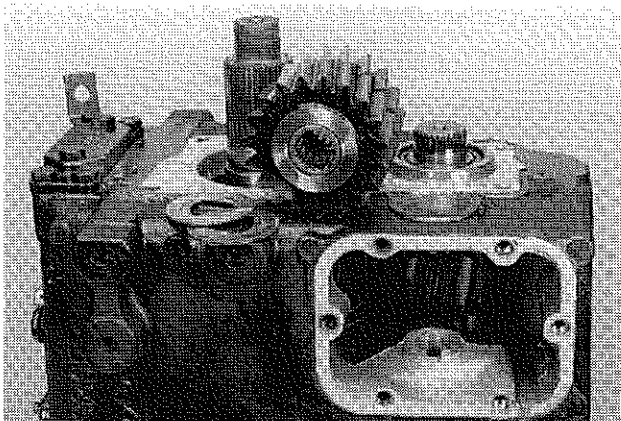

8. Remove the output bearing cap and gasket.

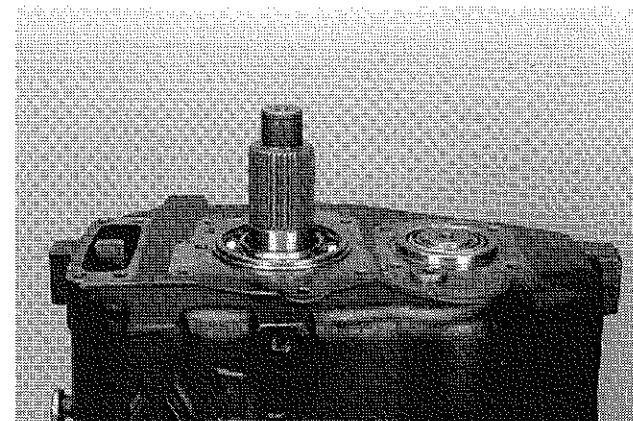

11. Remove the countershaft bearing cap and shims.

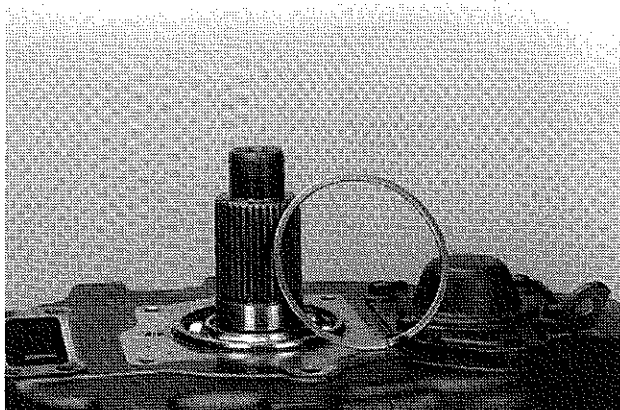

9. Remove the snap ring in the output bearing.

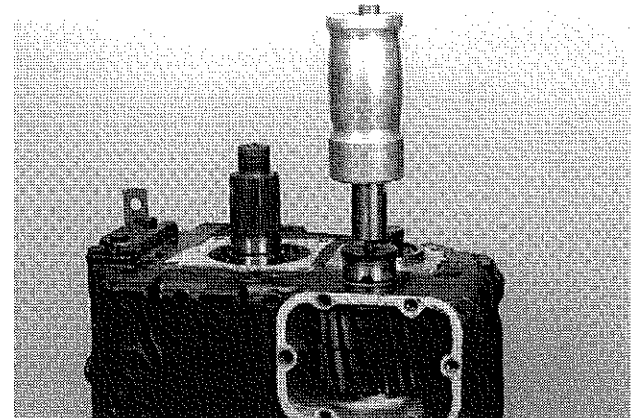

12. After removing the idler gear cover, insert a metric capscrew with a prying fixture into the reverse idler shaft.

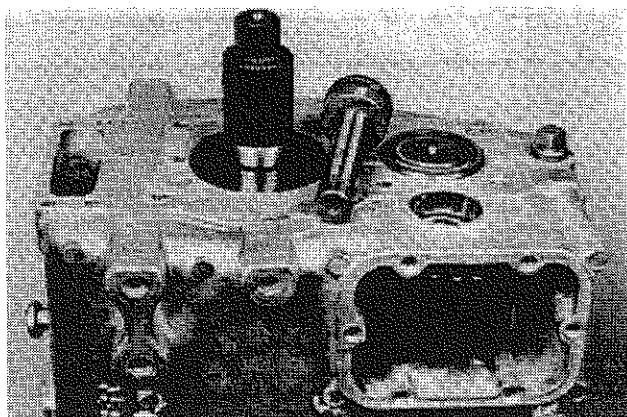

13. Remove the reverse idler shaft.

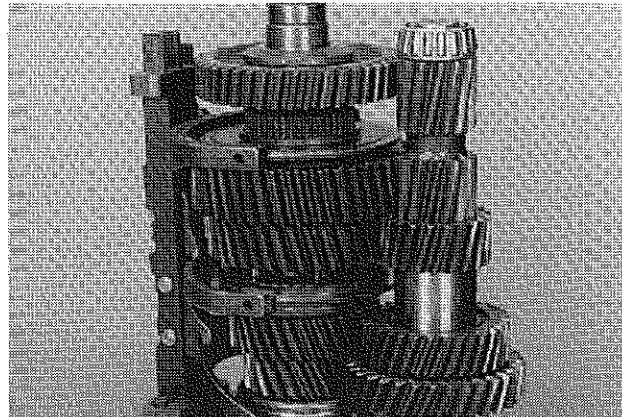

16. Remove the reverse gear with bearings and thrust washer.

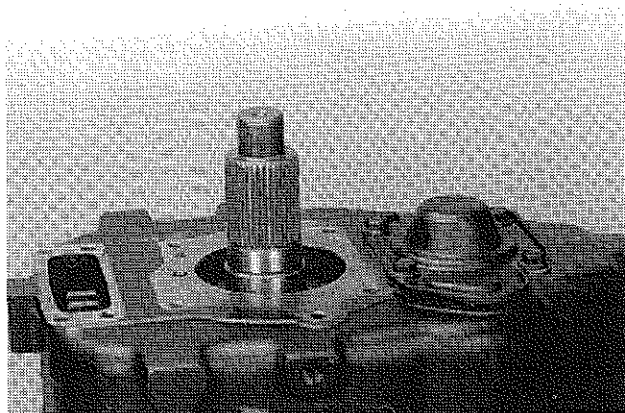

14. The reverse idler gear with thrust washers should be removed. This idler gear contains two bearings and a spacer in its bore.

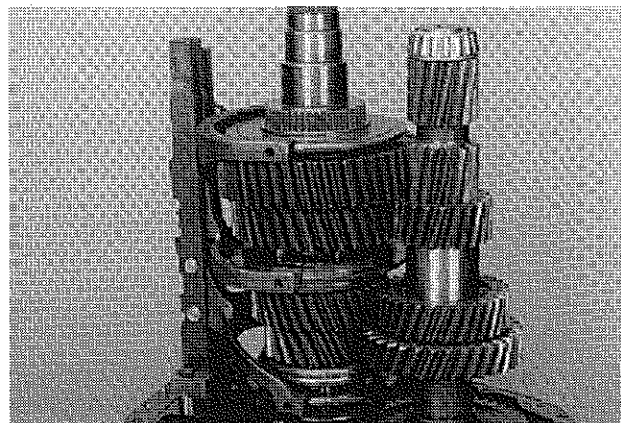

17. Now remove the shift bar support bracket, the 1st reverse clutch collar and the shift fork assembly.

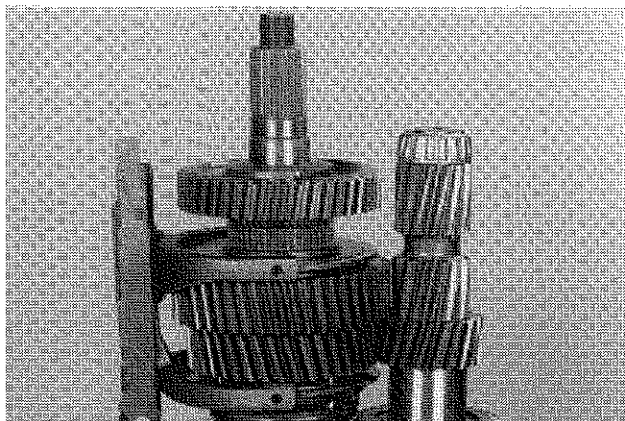

15. After removing the metric capscrews, lift the case from the clutch housing.

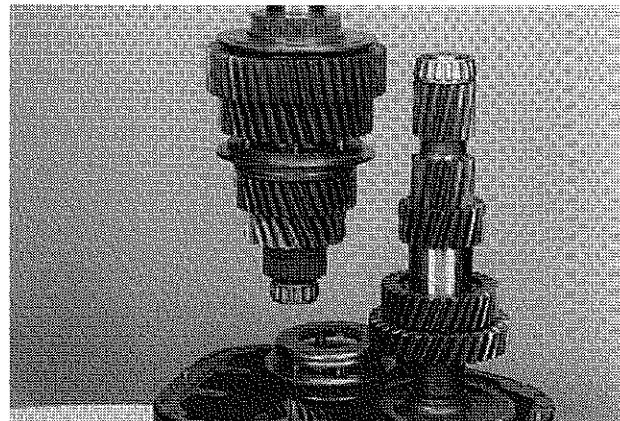

18. Lift the mainshaft sub-assembly away from the 4th-5th synchronizer.

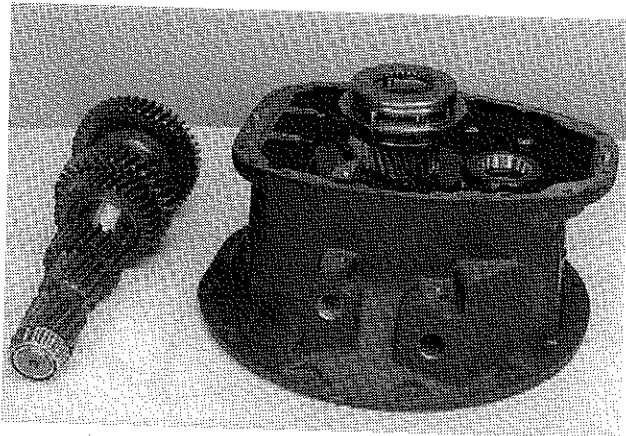

19. Remove the countershaft sub-assembly.

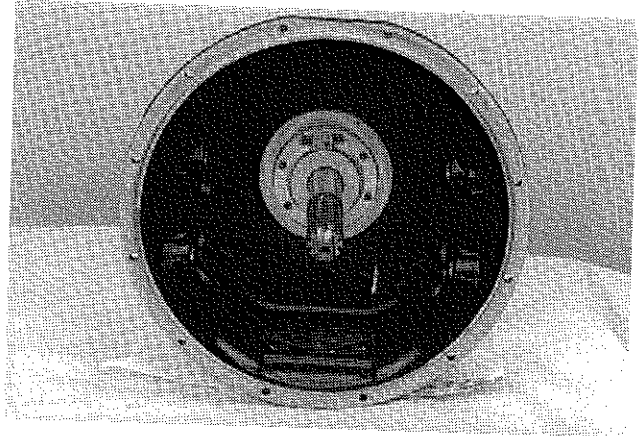

22. Remove the input bearing cap.

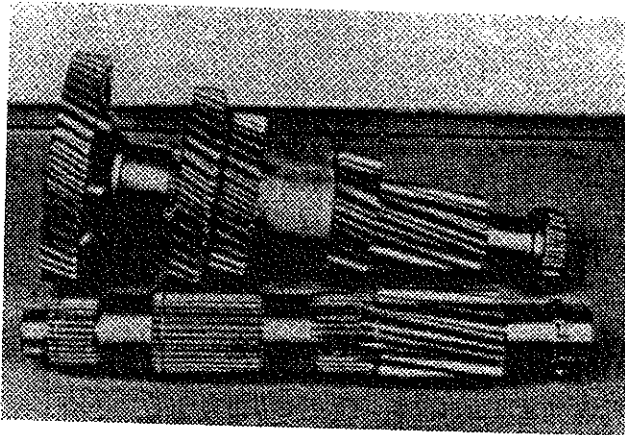

20. The countershaft utilizes rolled involute splines instead of woodruff keys.

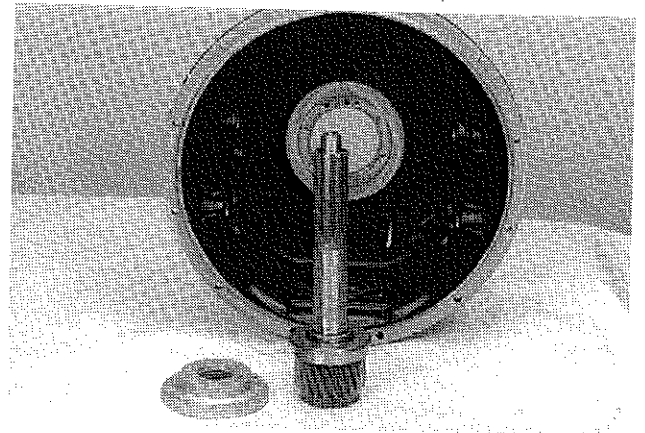

23. Then remove the input gear.

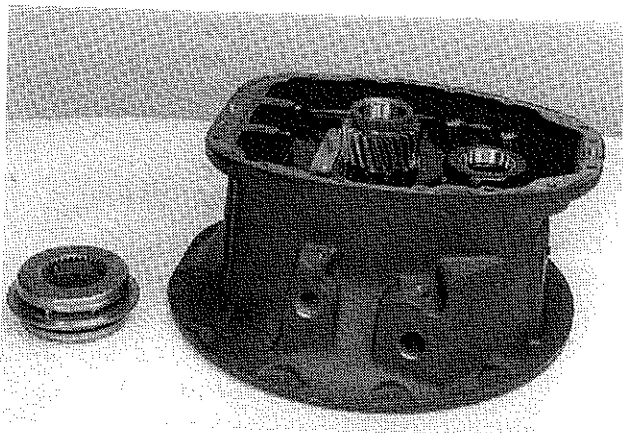

21. Remove the 4th-5th speed synchronizer and the shift fork assembly.

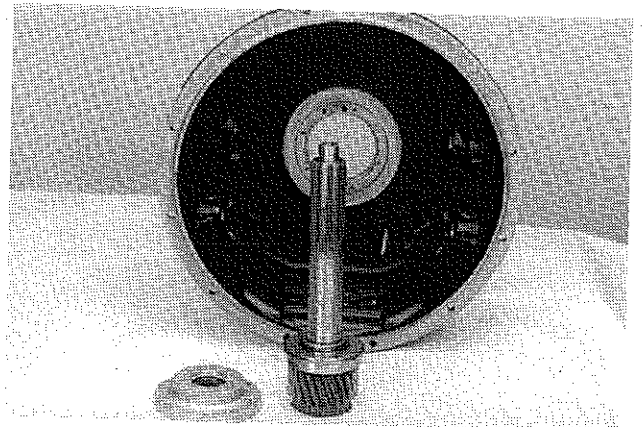

24. The input bearing can be replaced by first removing the oil slinger and snap ring, then pressing the shaft through this bearing.

GEAR GROUP

SECTION V

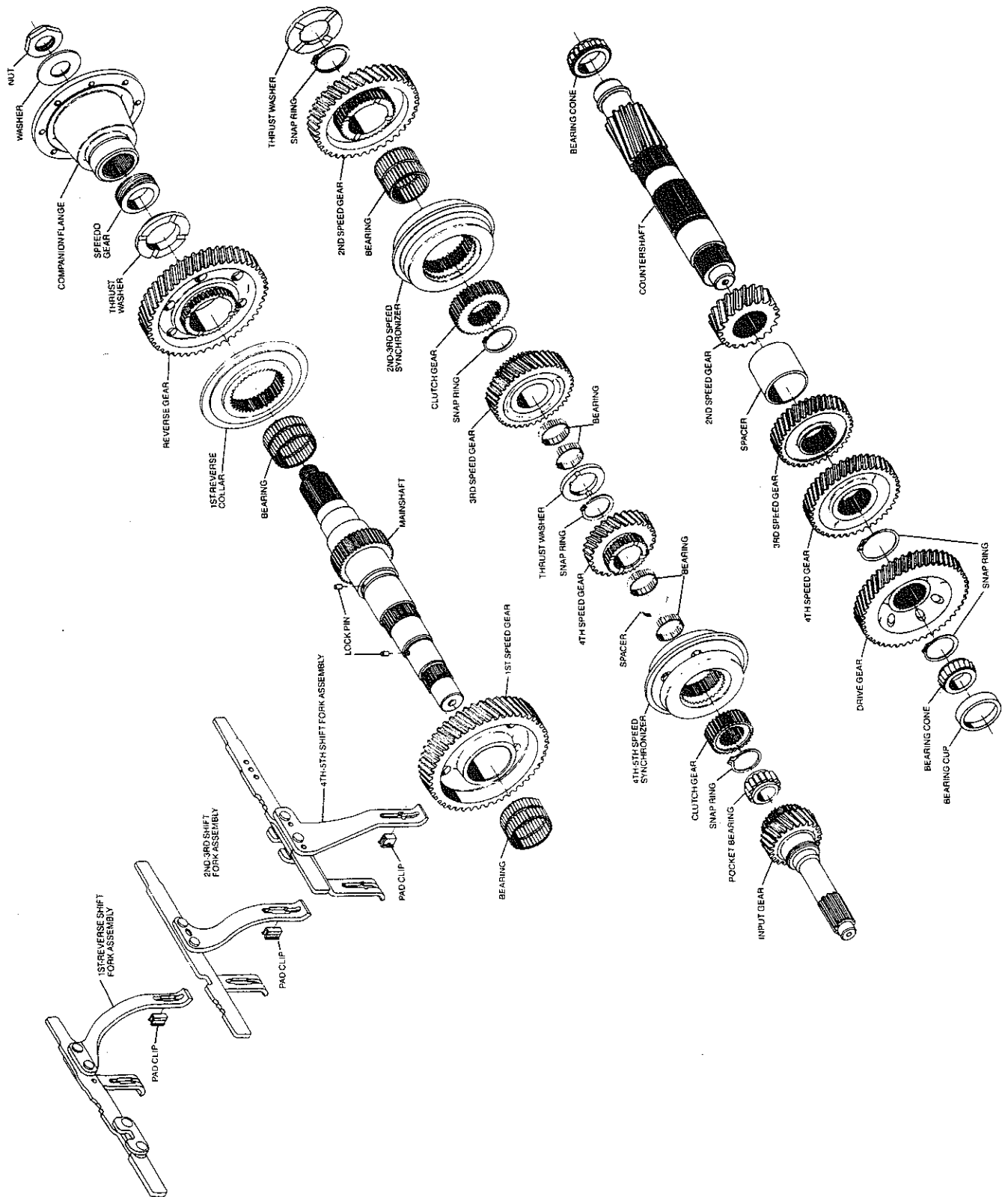

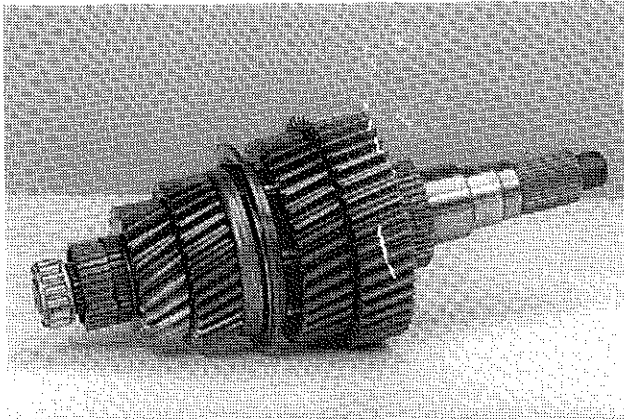

1. Place the mainshaft subassembly on a bench.

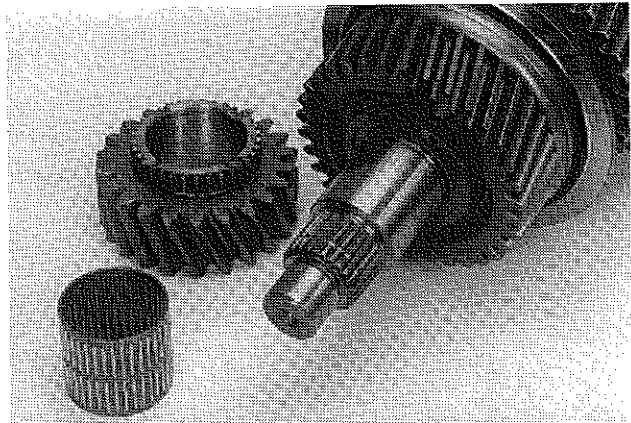

4. Remove the 4th speed gear and caged needle bearings.

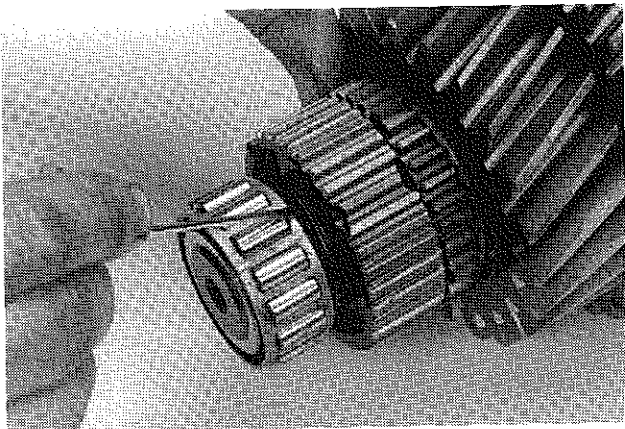

2. Remove the spiral snap ring from the groove. The easiest way to do this is to place a screwdriver under one end and work it around the snap ring.

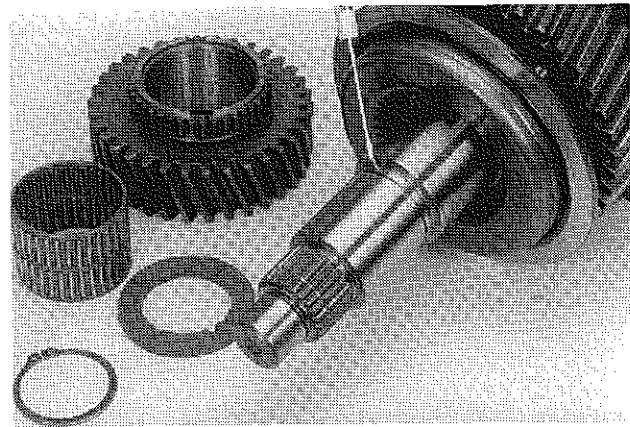

5. Now remove the snap ring, thrust washer, 3rd speed gear, and caged needle bearing. Notice the lock pin in the mainshaft: this pin prevents the thrust washer from turning, and can be removed now.

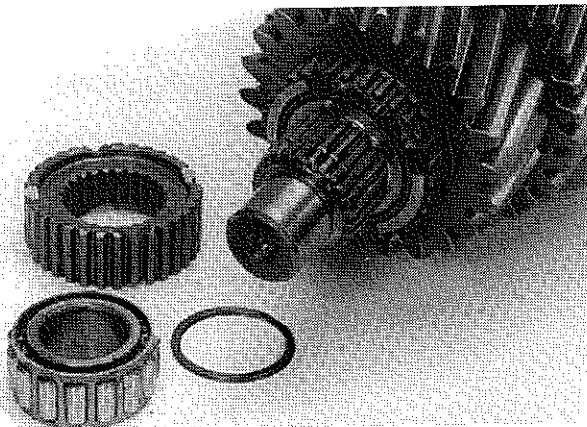

3. Next, attach a puller to the 4th-5th speed clutch gear. Remove the gear and the drive gear bearing together.

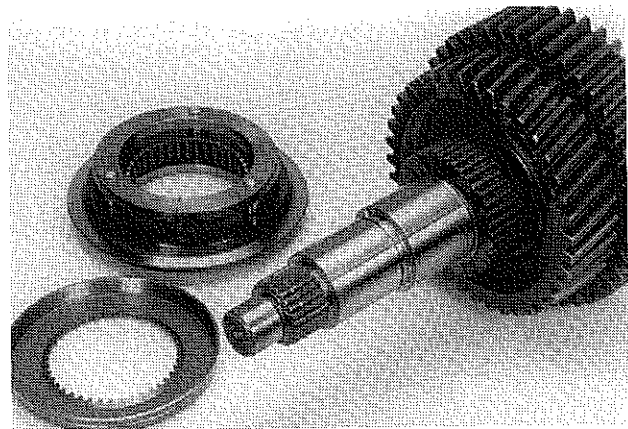

6. Remove the 2nd-3rd speed synchronizer.

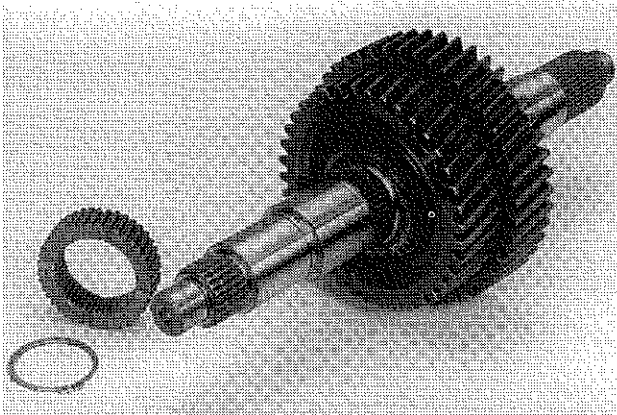

7. Now remove the snap ring and the 2nd-3rd speed clutch gear.



10. The mainshaft uses caged needle bearings under all gears.

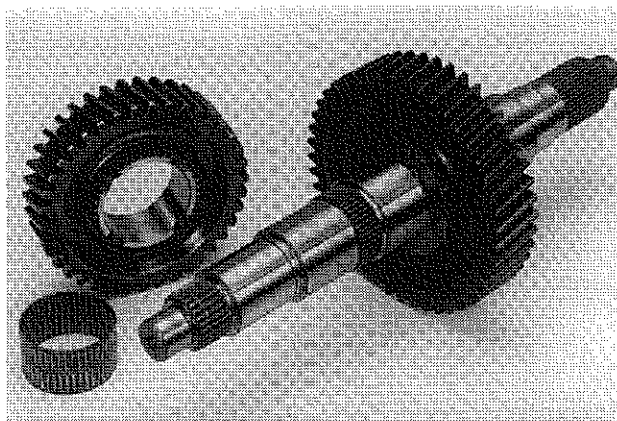

8. The 2nd speed gear and caged needle bearings can be lifted from the mainshaft.

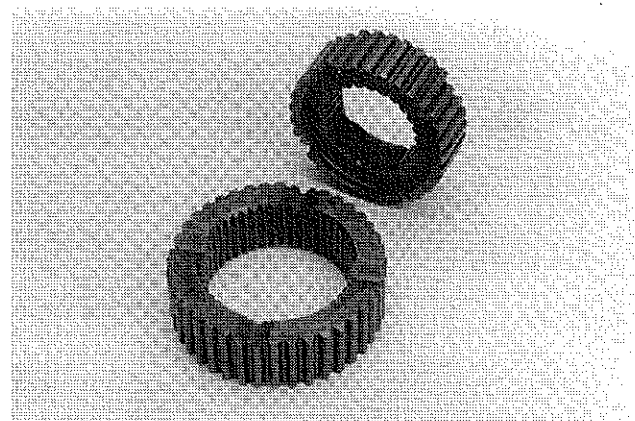

11. The clutch gears—not the mainshaft—contain the gear locks.

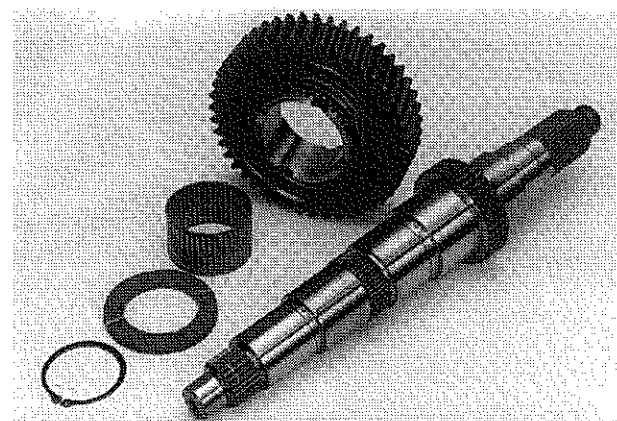

9. Remove the snap ring, thrust washer and 1st speed gear with caged needle bearings. The lockpin should also be removed now.

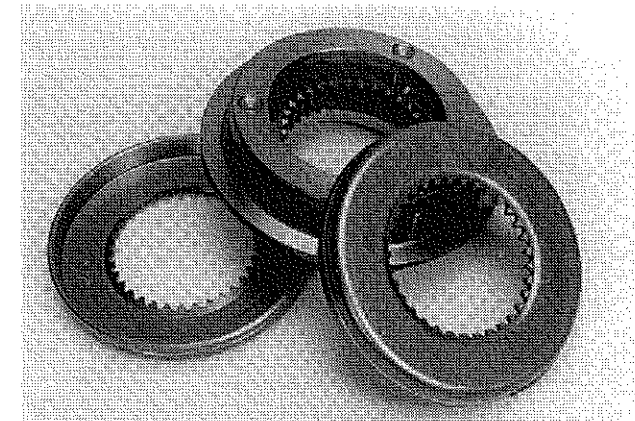

12. The synchronizers have separate clutching rings.



13. Begin reassembly by placing the mainshaft in an upright position. Also, coat all bearings with Moly #2 lubricant at this time.

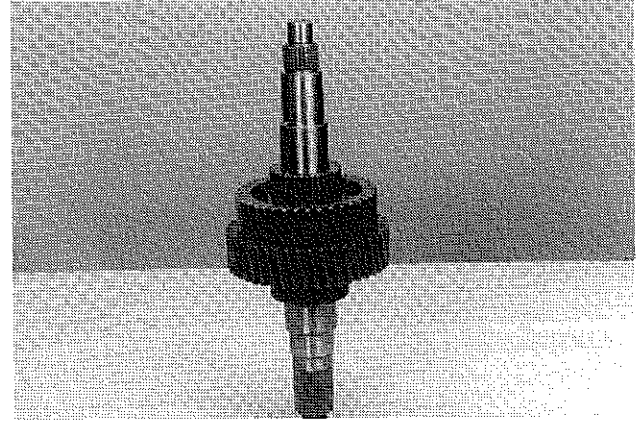

16. Install the reversible 2nd-3rd speed clutch gear and secure it with a snap ring.

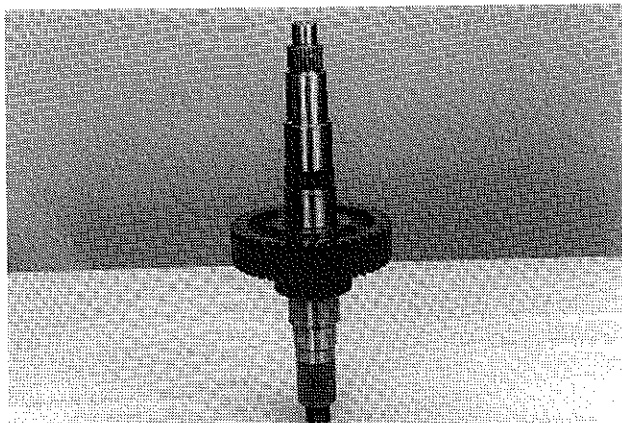

14. Assemble the 1st speed gear with the caged needle bearings, lock pin and thrust washer. Secure them with a snap ring. We recommend placing the die rolled side of the snap ring toward the needle bearing cage, where applicable.

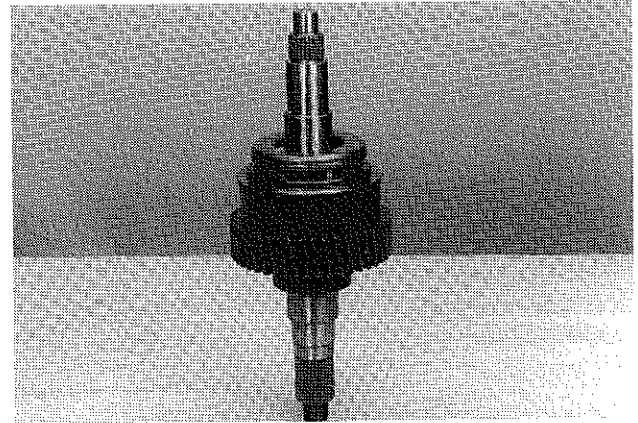

17. Next, slide the synchronizer onto the 2nd-3rd speed clutch gear. Note: On models ES52-5 and CM49 only, the longest synchronizer side should face second gear when the synchronizer is in neutral. (Refer to photo.)

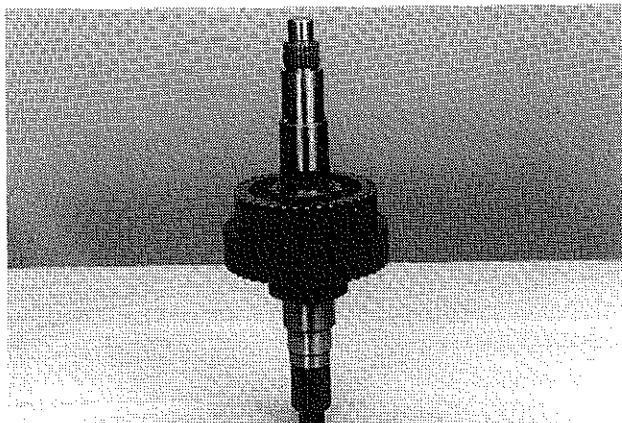

15. Place the 2nd speed gear over its caged needle bearings.

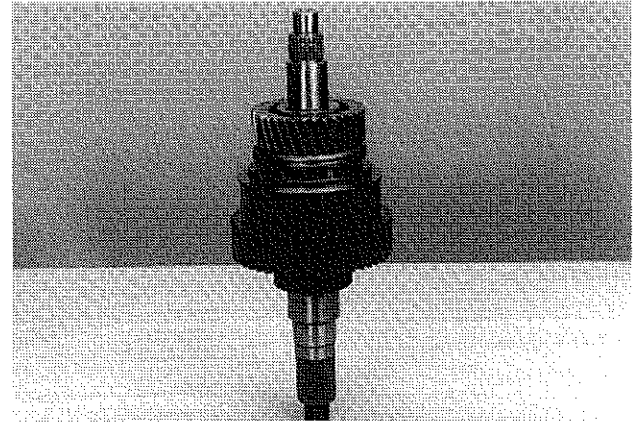

18. Install the 3rd speed gear, caged needle bearings, lock pin and thrust washer. Secure them with a snap ring. Again, place the die rolled side of the snap ring toward the needle bearing cage.

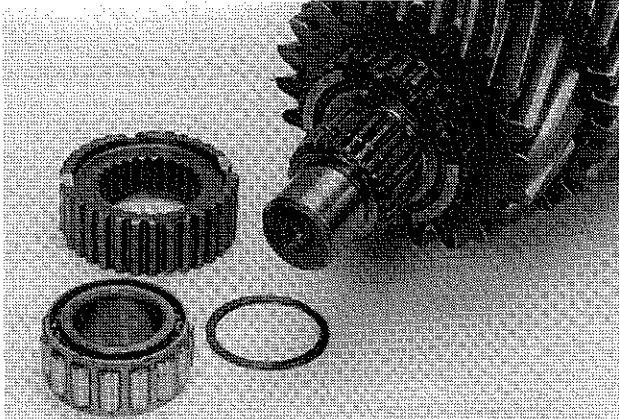

19. Now install the 4th speed gear and caged needle bearings.

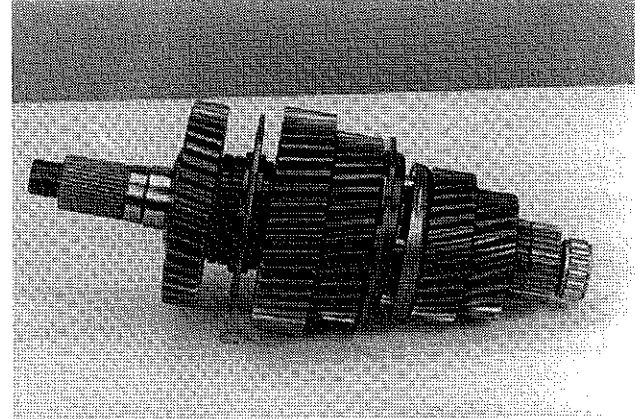

22. This completes the mainshaft reassembly.

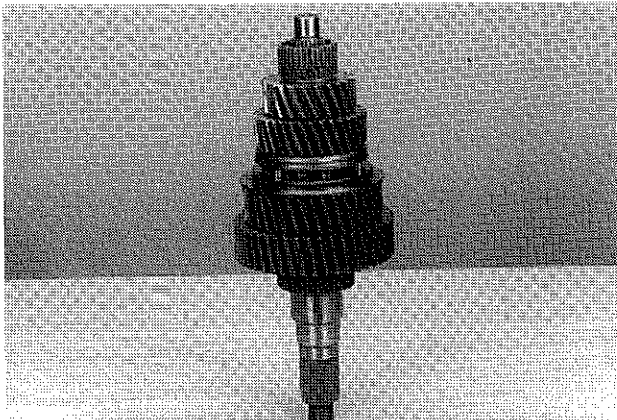

20. Slide the 4th-5th speed clutch gear onto the mainshaft and secure it with a spiral snap ring.

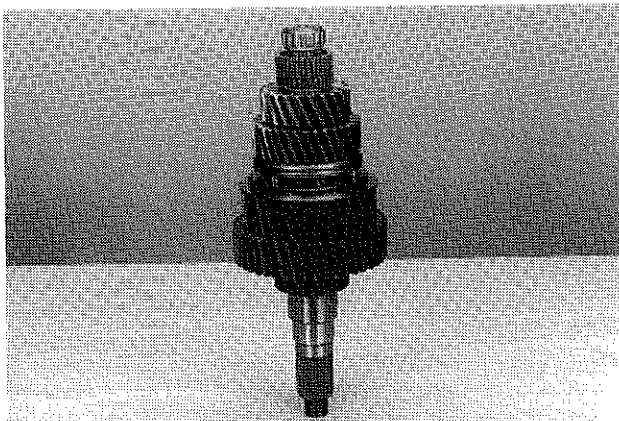

21. Install the pocket bearing, then pack it with Moly #2 lubricant.

Inspection

Prior to reassembling the mainshaft, certain individual parts should be examined. Parts damaged from previous service should be eliminated to insure maximum rebuild life.

These suggested inspection procedures should be followed:

Synchronizers: Both the internal and external teeth must have sharp edges. Rounded corners or excessive chipping will cause gear jumping. Also, examine synchronizer rings for metal contamination.

Gears: Examine for broken or cracked operating teeth. Also, check for any unusual wear patterns. Clutching teeth must not show excessive wear.

Thrust Washers: Check for flatness or excessive face wear (cracks, scoring, etc.)

Snap Rings: Examine for distortion or loss of tension. New snap rings are recommended with every rebuild.

Mainshaft: Check clutch gear spline gearlocks for sharp corners. Worn or ironed out gearlocks will produce gear jumping. Also, check for chipped splines at snap ring grooves. Apply a coating of moly grease to all fluted diameters.

RECOMMENDED WRENCH TORQUE LOADS FOR PREVAILING TORQUE THREADED FASTENERS

These limits represent the wrench torque values required to offset the maximum prevailing torque expected during the initial installation and to obtain clamping forces comparable to those encountered when CHT-700 sheet #1 values are applied to plain fasteners.

Note: These values are based upon the wrench torque values recommended and the maximum prevailing torque values.

NOM. SIZE (DIA.)	PART NAME	WRENCH TORQUE FT. LBS.	
		MIN.	MAX.
.250 & 6MM	Cap Screw or Nut	10	13
.312	Cap Screw or Nut	20	24
* .375 & 10MM	Cap Screw or Nut	34	41
** .438	Cap Screw or Nut	52	62
12MM	Cap Screw or Nut	60	80
.500	Cap Screw or Nut	78	98
14MM	Cap Screw or Nut	80	100
.562	Cap Screw or Nut	112	137
.625	Cap Screw or Nut	150	180
.750	Cap Screw or Nut	240	290

*NOTE: On P.T.O. aperture cover 50-267-2 with gasket 46-324-1 the torque on the .375 dia. capscrews should be 19-24 ft. lbs.

**NOTE: On P.T.O. aperture cover 73-267-1 with gasket 22P22 the torque on the .438 dia. capscrews should be 29-34 ft. lbs.

**NOTE: For forks or shift brackets the torque on .438 dia. lock screws should be 34-41 ft. lbs.

For the 60-16-63 transmission cover the tightening torque for the .438 dia. mounting screws should be 25-32 ft. lbs.

Note: Throughout the reassembly section of this manual, Loctite "515" gasket eliminator compound is used as a sealant unless a gasket is mentioned in conjunction with a picture.

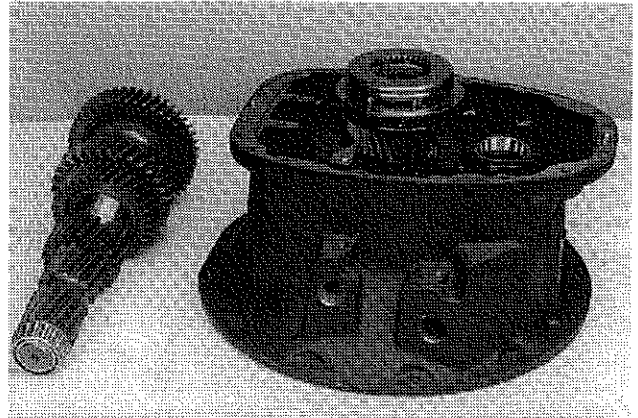

3. Place the 4th-5th speed synchronizer onto the input gear along with the shift fork assembly.

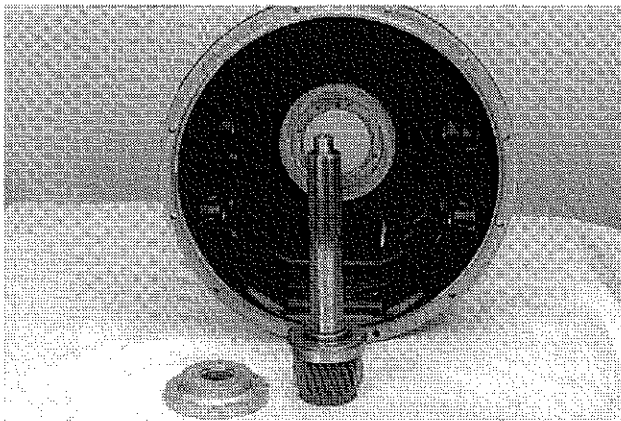

1. Place the input shaft subassembly into the clutch housing.

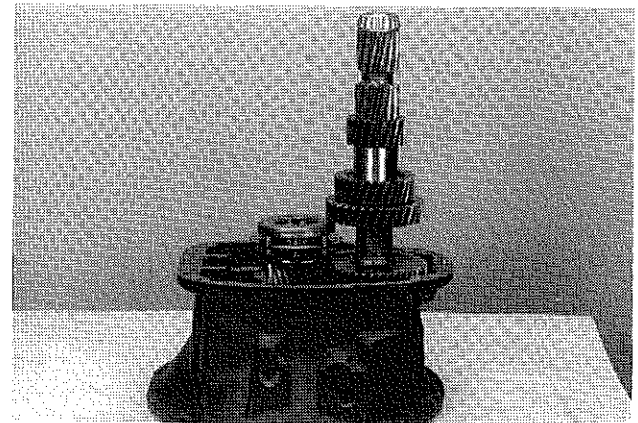

4. Set the countershaft subassembly into the clutch housing.

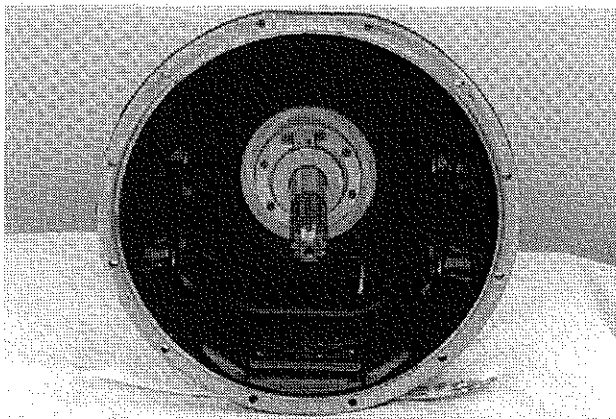

2. Install the input bearing cap and secure it with the hex head capscrews.

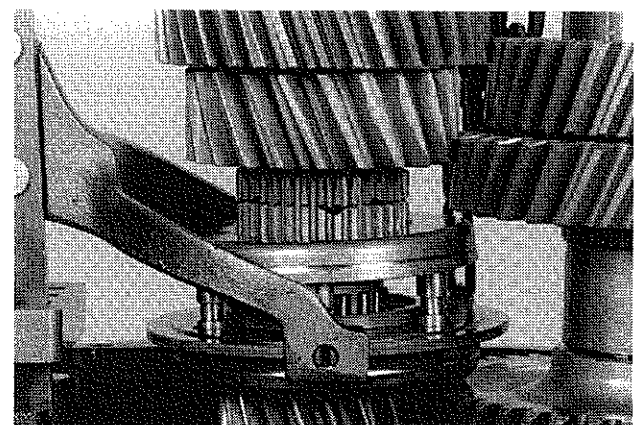

5. Engage the 4th-5th synchronizer in 5th gear.

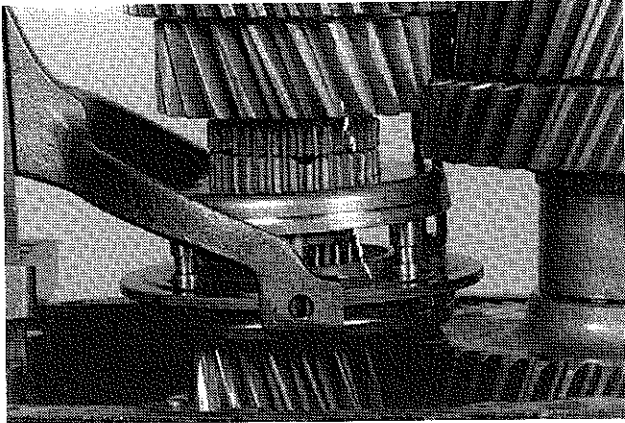

6. Keep the 4th-5th speed clutch gear splines in alignment with the 4th gear clutching teeth, while lowering the mainshaft subassembly. This will make installation easier, while preventing pocket bearing damage.

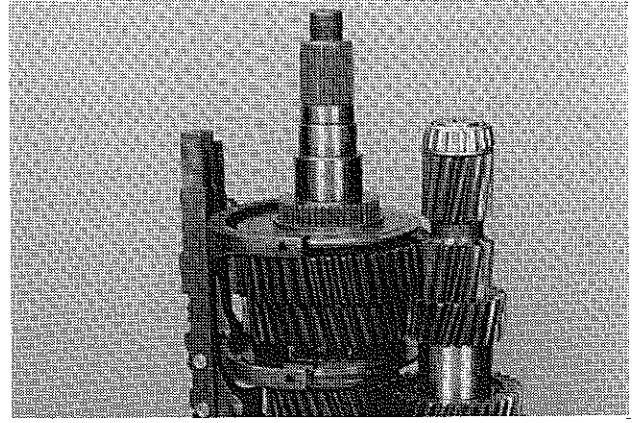

9. Install the 1st-reverse clutch collar with the shift fork assembly.



7. Lower the mainshaft subassembly into position.

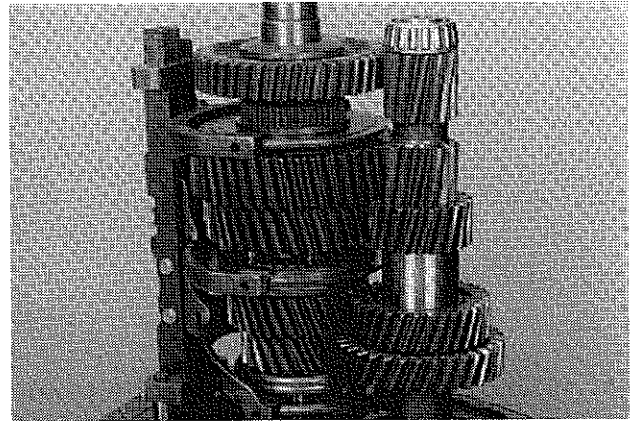

10. Install the reverse gear, caged needle bearings and thrust washer (flat side against reverse gear).

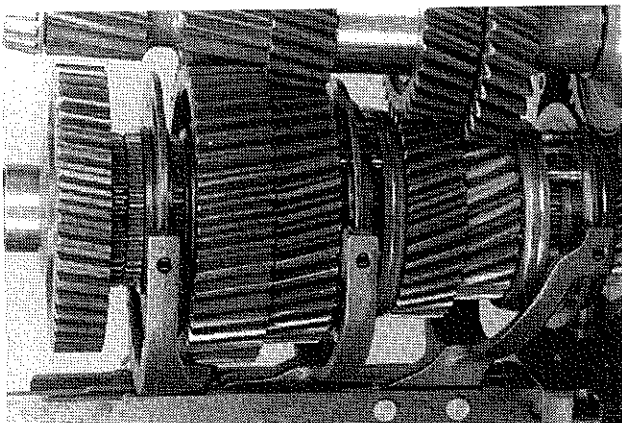

8. Engage the transmission in neutral once the mainshaft is in place.

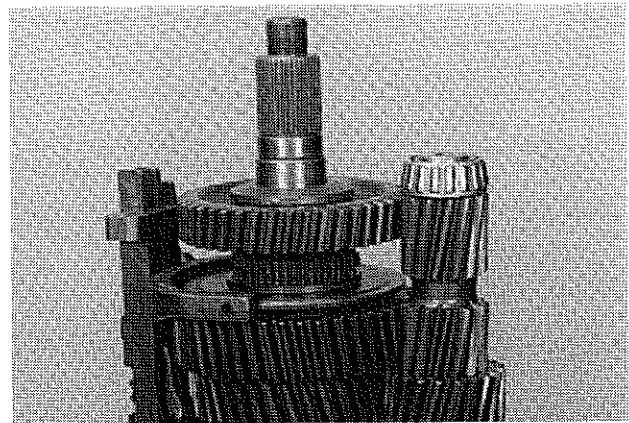

11. **Caution:** Be sure to place the shift bar rear support bracket into its proper position before lowering the case over the gear assembly.

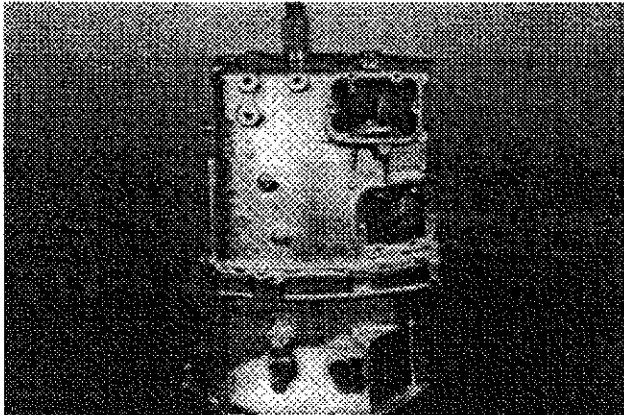

12. Lower the case and secure it with the metric capscrews.

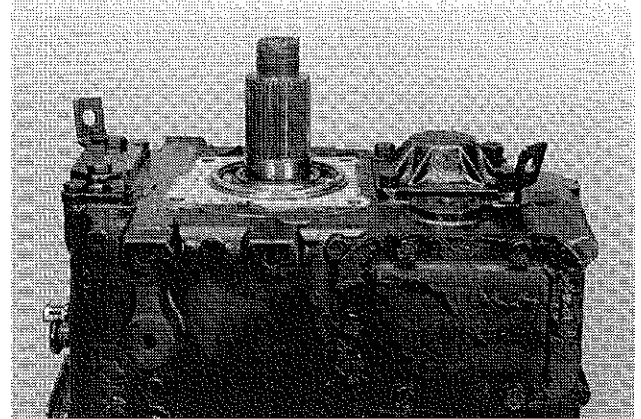

15. Install the countershaft bearing cap and shims.

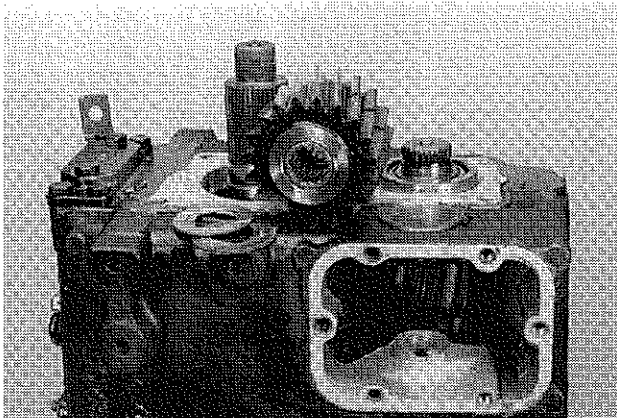

13. Install the reverse idler gear with the spacer, bearings and thrust washers. Also, the countershaft bearing cap may be installed now.

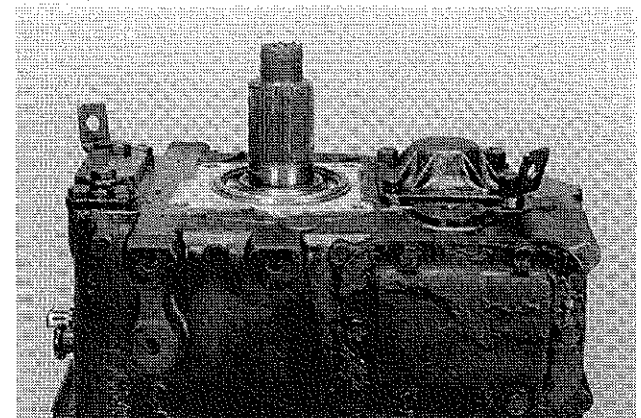

16. Assemble the reverse idler gear cover to the case.

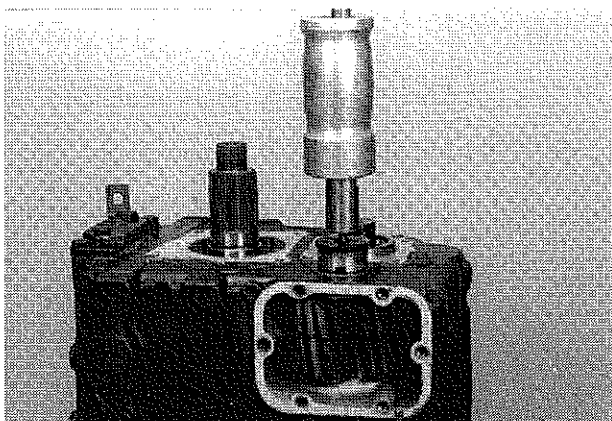

14. Insert the reverse idler shaft with the flat side toward the countershaft bearing cap. Then drive this shaft into position.

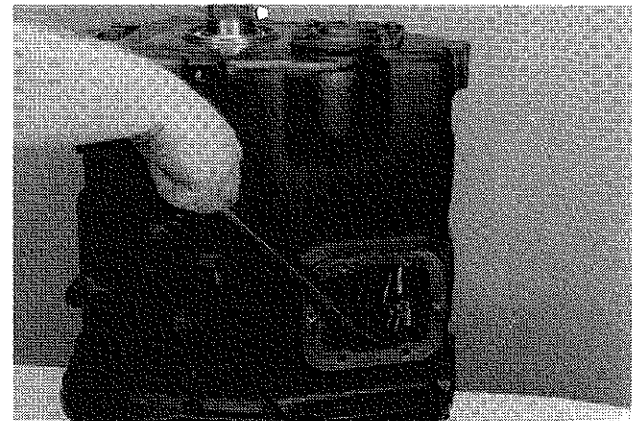

17. Now check the countershaft end play through the PTO aperture. **End play must be set between .001 - .008.** If it is not correct make adjustments by either adding or removing shims under the countershaft bearing cap. When finished, install the PTO aperture covers.

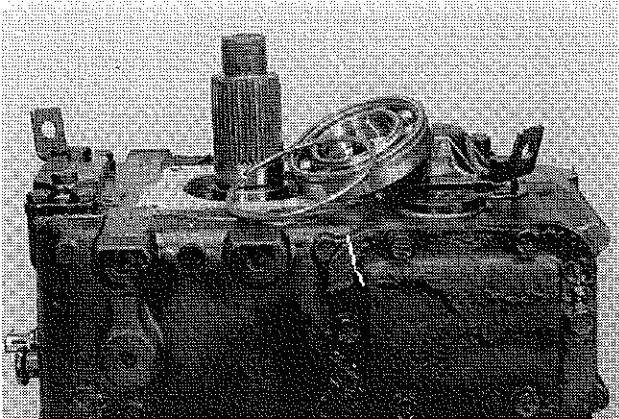

18. Install the output bearing.

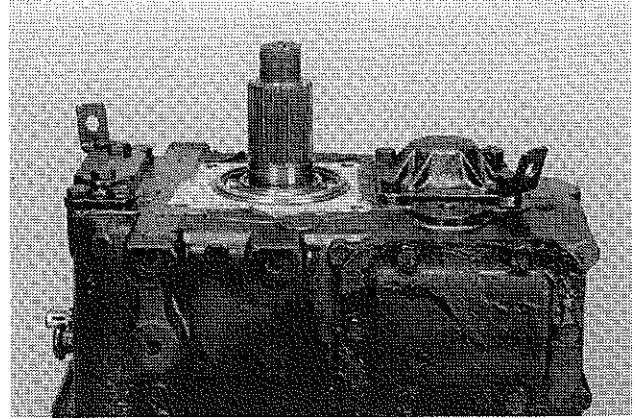

21. Now secure the end cap with capscrews.

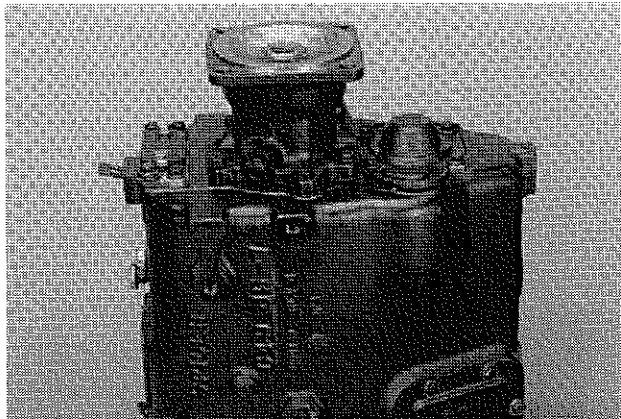

19. Assemble the output bearing cap and gasket to the case.

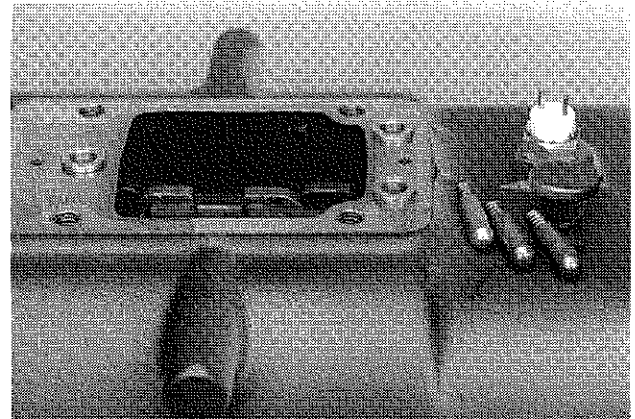

22. Reinstall the backup light switch, and the three poppet balls and springs.



20. Insert a capscrew into the shift bar support bracket. Then lift the screw: this allows the bracket to be raised to its proper position.

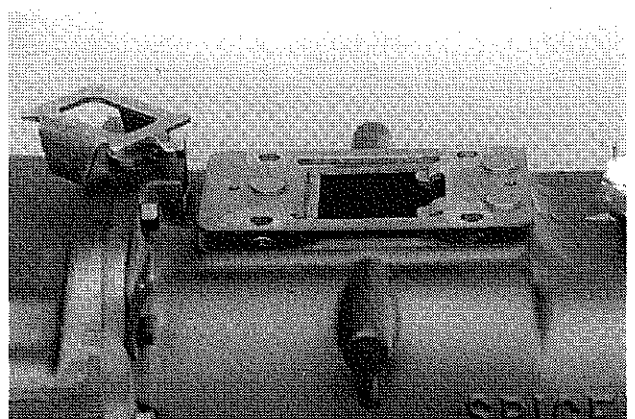

23. Install the gasket and retaining plate. Then place the interlock into its proper position.



24. Assemble the shift tower and gasket.

Important Procedure

When locating and correcting unit power or auxiliary transmission troubles, a systematic procedure should be followed.

Road test whenever possible. Mechanics usually get second or third hand reports of trouble experienced with the unit. These reports do not always accurately describe the actual conditions. Sometimes symptoms seem to indicate trouble in the transmission, while actually the problem is with the axle, driveshaft, universal joints, engine or clutch. This is especially true of noise complaints. Therefore, before removing the transmission or related components to locate trouble, road test to check the possibility of trouble in other closely associated units. Road testing is most effective when the mechanic himself drives the vehicle. However, riding with the driver can be very informative.

Check Functioning Prior to Disassembly

If a remote control is used, a careful check of the remote and connecting linkage must be made. The remote unit must be in good working order if the transmission is expected to shift satisfactorily.

Many times, the answer to the trouble is apparent when the unit is inspected prior to disassembly. But this evidence is often lost when the parts are separated. If possible, check the unit prior to disassembly. Bear in mind that a careful inspection of the unit should be made as each disassembly step is performed.

Inspect Thoroughly During Disassembly

It is poor practice to disassemble a unit or the complete transmission as quickly as possible without examining the parts. The mechanic may completely disassemble a unit and fail to find the cause of the trouble, unless he examines the parts. After the transmission is disassembled, check the lubricant for foreign particles. This is a source of trouble often overlooked during the disassembly.

Repair or Replace Worn Parts

Many times the parts or critical adjustments causing the trouble are not replaced or corrected because the mechanic only inspects and replaces parts that have failed completely. *All* pieces should be accurately examined because broken parts are often just the result—not the cause—of the problem. All parts that are broken or worn and no longer meet specifications should be replaced.

Also, parts that are worn to the extent that they do not have a long service life remaining should be replaced. Replacing these parts now will avoid another teardown on the unit in the near future. Also at this time, make the recommended changes or modifications to bring the transmission up to date and increase the service life of the unit.

CAUTION: If the backup lights do not function, check the following:

1. Continuity of switch with ball fully depressed
2. Electrical plug connection
3. Wiring

Noisy Operation

Noise is usually a very elusive problem, and is generally not the fault of the transmission. Mechanics should road test the vehicle to determine if the driver's complaint of noise is actually in the transmission.

In numerous instances drivers have insisted noise was coming from the transmission, investigations revealed it was caused by one of the following conditions:

- (a) Fan out of balance or blades were bent.
- (b) Defective vibration dampers.
- (c) Crankshaft out of balance.
- (d) Flywheel out of balance.
- (e) Loose flywheel mounting bolts.
- (f) Rough engine idle producing rattle in gear train.
- (g) Clutch assembly out of balance.
- (h) Loose or broken engine mounts.
- (i) Power take-off was engaged.
- (j) Worn universal joints.
- (k) Driveshaft out of balance.
- (l) Universal joint angles out of plane or at excessive angles.
- (m) Center bearings in driveline dry, not mounted properly.
- (n) Wheels out of balance.
- (o) Tire treads humming or vibrating at certain speeds.
- (p) Air leaks on suction side of induction system, especially with turbo-chargers.

Mechanics should try to locate and eliminate noise by means other than a transmission removal or an overhaul. However, if the noise appears to be in the transmission, try to determine what position the gear shift lever is in when the noise occurs. If the noise is evident in only one gear position, the problem is generally traceable to the operating gears. Next, try to break the noise down into the following classifications:

- (a) *Growling, humming and grinding.* These noises are caused by worn, chipped, rough or cracked gears. As gears continue to wear, the grinding noise will be noticeable, particularly in the gear position that throws the greatest load on the worn gear.

A lack of lubricant or use of improper lubricant can also result in growling and grinding noises. This is because there is insufficient lubricant to cool and cover the gears, which allows metal-to-metal contact.

- (b) *Hissing, thumping and bumping.* Hissing noises can be caused by bad bearings. As bearings wear and retainers start to break up, etc., the noise could change to a thumping or bumping.

- (c) *Gear whine.* This is usually caused by lack of backlash between mating gears. Improper PTO shimming is the big offender here.

- (d) *Vibration.* Today's improved highways mean entire power trains are cruising at higher RPMs. These higher speeds mean damage caused by driveline vibration is more obvious than in the past.

When the maximum RPM of a shaft is reached, it begins to bow. A resonant hum can be heard, and a vibration will be set up. This type vibration can cause gear seizures, broken synchronizer pins, bearing failures, brinelling and corrosion.

During acceleration and deceleration, the shaft may pass through half-critical vibration (half the maximum RPM of the shaft). A whine or boom may be heard at this point.

- (e) *Metallic rattles.* These noises within the transmission usually result from a variety of conditions. Engine torsional vibrations are transmitted to the transmission through the clutch. In heavy duty equipment, clutch discs with vibration dampers are not used, so a rattle—particularly in neutral—is common with diesel equipment.

In general, engine speeds should be 600 RPM or above to eliminate objectionable rattles and vibration during the idle. A defective or faulty injector would cause a rough or lower idle speed, and possibly a rattle in the transmission. A rattle can also be caused by excessive backlash between the PTO input gear and the transmission output gear.

Noise in Neutral

Possible Causes:

- (a) Misalignment of transmission.
- (b) Worn flywheel pilot bearing.
- (c) Worn or scored countershaft bearings.
- (d) Worn or rough reverse idler gear.
- (e) Sprung or worn countershaft.
- (f) Excessive backlash in gears.
- (g) Worn mainshaft pilot bearing.
- (h) Scuffed gear tooth contact surface.
- (i) Insufficient lubrication.
- (j) Use of incorrect grade of lubricant.

Noise in Gear

Possible Causes:

- (a) Worn or rough mainshaft rear bearing.
- (b) Rough, chipped, or tapered sliding gear teeth.
- (c) Noisy speedometer gears.
- (d) Excessive end play of countershaft gears.
- (e) Refer to conditions listed under *Noise in Neutral*.

Oil Leaks

Possible Causes:

- (a) Oil level too high.
- (b) Wrong lubricant in unit.
- (c) Non-shielded bearing used as front or rear bearing cap where applicable.
- (d) Seals defective, wrong type or omitted from bearing cap.
- (e) Transmission breather omitted or plugged internally.
- (f) Capscrews loose, omitted or missing from remote control, shifter housing, bearing caps, PTO or covers.
- (g) Oil drain-back openings in bearing caps or case plugged with varnish, dirt, or gasket material.
- (h) Gaskets shifted or squeezed out of position, broken gaskets with pieces still under bearing cap, clutch housing, PTO and covers.
- (i) Cracks or holes in castings.
- (j) Loose drain plug.
- (k) Oil leakage from engine.
- (l) Loose speedometer adaptor or connections.

Walking or Jumping Out of Gear

If the units are walking out of gear, it could be caused by:

- (a) External interference, such as the floorboard opening, preventing full engagement, *or*
- (b) An internal malfunction, such as worn clutching teeth, allowing the transmission to shift out of position.

If a remote control is being used, make sure it is functioning properly before the transmission is blamed for the problem. Note whether the unit walks out of gear under drive while pulling a load, or on a coast load. Also, notice whether the gear hop occurs on smooth roads or only on rough roads. Items that would prevent full engagement of gears are:

- (a) Improperly positioned forward remote control which limits full travel forward and backward from the remote neutral position.
- (b) Improper length shift rails or linkage that limits travel of forward remote from neutral position.
- (c) Loose bell cranks, sloppy ball and socket joints.
- (d) Shift rails, cables, etc., too spongy or flexible, or not secured properly at both ends.
- (e) Worn or loose engine mounts if forward unit is mounted to frame.
- (f) Forward remote mount too flimsy, or loose on the frame.
- (g) Set screws loose at remote control joints, on shift forks inside remote or even inside transmission unit.
- (h) Shift fork pad clips or groove in sliding gear or collar worn excessively.
- (i) Worn taper on gear clutch teeth.
- (j) Transmission and engine out of alignment either vertically or horizontally.

A few items which could move the gear or shaft out of proper position, particularly on rough roads are:

- (a) Use of heavy shift lever extensions.
- (b) Broken shift rail poppet springs.
- (c) Worn shift rail poppet notches.
- (d) Bent or sprung shift rails.
- (e) Shift fork pad clips broken or missing.
- (f) Excessive end-play in drive gear, mainshaft or countershaft, caused by worn bearings or retainers.
- (g) Worn or missing thrust washers.

Hard Shifting

An improperly operating clutch will interfere with the proper shifting of gears in any transmission. It is also important that the hydraulic, air or similar release mechanism is in proper working order. If full and complete clutch release is being made, the following could be a few of the possible causes for hard shifting complaints:

- (a) No lubricant in remote control unit. (Note: The forward remote is isolated and is often overlooked. Many remote controls used on transmissions and auxiliaries require separate lubrication.)
- (b) No lubricant in, or grease fittings on, u-joints or swivels of remote controls.
- (c) Lack of lubricant or wrong lubricant used, causing buildup of sticky varnish and sludge deposits on splines of shaft and gears.
- (d) Badly worn or bent shift rails.
- (e) Improper adjustment on shifter linkage.
- (f) Sliding clutch gears tight on splines of shaft.
- (g) Clutch teeth burred over, chipped or badly mutilated because of improper shifting.
- (h) Binding or interference of shift lever with other objects or rods inside the cab or near the remote control island.
- (i) Driver not familiar with proper shifting procedure for the transmission, or with 2-speed axle or auxiliary.
- (j) Clutch or drive gear pilot bearing seized, rough, or dragging.
- (k) Clutch brake engaging too soon when clutch pedal is depressed.
- (l) Wrong lubricant, especially if extreme pressure type lubricant is added.
- (m) Free running gears seized or galled on either the thrust face or diameters.

Sticking in Gear

- (a) Clutch not releasing. Also check remote units such as hydraulic or air assist. **Note:** On some units employing a full air control for clutch release, air pressure of approximately 60 lbs. or more must be secured before the clutch can be released. **Do not leave these vehicles parked in gear.**
- (b) Sliding clutch gears tight on splines.
- (c) Chips wedged between or under splines of shaft and gear.
- (d) Improper adjustment, excessive wear or lost motion in shifter linkage.
- (e) Clutch brake set too high on clutch pedal, locking gears behind hopping guards.

Bearing Failures

The service life of most transmissions, main and auxiliary, is governed by the life of the bearings. The majority of bearing failures can be attributed to vibration and dirt. Some other prominent reasons for unit bearing failures are:

- (a) Fatigue of raceways or balls.
- (b) Wrong type or grade of lubricant.
- (c) Lack of lubricant.
- (d) Broken retainers, brinelled races and fretting caused by vibration.
- (e) Bearings set up too tight or too loose.
- (f) Improper installation resulting in brinelled bearings.
- (g) Improper fit of shafts or bore.
- (h) Acid etching due to water in lube.
- (i) Vehicle overload or too large an engine for the transmission resulting in overload.

Dirt

More than 90% of all ball bearing failures are caused by dirt, which is always abrasive.

Dirt may enter the bearings during assembly of units, or may be carried into the bearing by the lubricant while in service. Dirt also may enter bearings through seals, the breather or even dirty containers used for addition or change of lubricant.

Softer material, such as dirt or dust, usually forms abrasive paste or lapping compounds within the bearings. The pressure between the balls and raceways makes a perfect pulverizer: The rolling motion tends to entrap and hold the abrasives. As the balls and raceways wear, the bearings become noisy. The lapping action tends to increase rapidly as the fine steel from the balls and rollway adds to the lapping material.

Hard, coarse material, such as metal chips, may enter the bearings during assembly from tools such as hammers, drifts, and power chisels. It may also be manufactured within the unit during service from raking teeth. These chips produce small indentations in balls and races. When these hard particles jam between the balls and races, it may cause the inner race to turn on the shaft, or the outer race to turn in the housing.

Fatigue

All bearings are subject to fatigue and must be replaced eventually. Your own operating experience will dictate mileage replacement of bearings showing only normal wear.

Corrosion

Water, acid and corrosive materials formed by deterioration of lubricant, will produce a reddish-brown coating and small etched holes over outer and exposed surfaces of the race. Corrosive oxides also act as lapping agents.

Shaft Fits

Bearing fits on rotating shafts are usually specified as tight. Excessive looseness—even .001"—under a load, produces a creeping or slipping of the inner race on the rotating shaft. The result is that surface metal of the shafts scrub or wear off. The force causing the inner race to rotate disappears when the bearing fits properly.

Installation and Removal of Bearings

Improper installation or removal of bearings, especially hammering the bearing on the shaft with off-center blows, can result in brinelling. Since such damage is seldom visible, it does not become known until after failure or complete disassembly. The correct drivers (preferably under an arbor press) and pullers should be used.

Removing bearings is more difficult than installing them. In most cases, it is necessary to remove the bearing by pulling on the outer race, which can damage the balls or races. Therefore, it is a good idea to replace bearings during an overhaul, to prevent problems. However, if a bearing is not going to be replaced, avoid removal during low mileage rebuilds.

Interchangeability

All ball bearings, whether manufactured here or abroad, are interchangeable in regard to standardized dimensions, tolerances, and fits. However, for a given shaft size there are standard bearings for light, medium, and heavy duty service.

Numbers and symbols stamped on inner and outer races of bearings designate size and type. Note that the numbering systems of different bearing manufacturers have not been standardized. Consult interchangeable tables and use the proper bearings for replacement parts.

Clutch Troubleshooting

Faulty clutch operation interferes with proper shifting of gears in any transmission. For complete information on Spicer clutches, refer to bulletins 1302 and 1308. If a clutch other than a Spicer is used with this transmission, refer to the manufacturer's service manual for correct adjustment and maintenance. The two following paragraphs describe the most common problems encountered with Spicer clutches.

- (a) If the clutch slips or does not engage properly, first check the internal clutch adjustment. If adjustment does not remedy the situation, check for weak pressure springs, lack of free pedal, and worn or oily clutch facings and binding release mechanism.
- (b) If the clutch drags or does not release properly, check the internal clutch adjustment. Some other causes for clutch drag are: an intermediate plate sticking on drive pins or drive lugs; the pressure plate not retracting; a distorted or warped driven disc; worn splines on the main drive gear of the transmission; a damaged clutch release bearing; or the bushing in the release sleeve may be dragging on the transmission drive gear.



14700 Helm Court
Plymouth, MI 48170
(800) 401-9866 or (734) 456-3770
Fax: (734) 456-3739
www.ttcautomotive.com

